



US008984800B2

(12) **United States Patent**
Canfield et al.

(10) **Patent No.:** **US 8,984,800 B2**
(45) **Date of Patent:** **Mar. 24, 2015**

(54) **RADIATING SYSTEMS FOR AFFECTING INSECT BEHAVIOR**

(71) Applicant: **Technology SG, L.P.**, West
Conshohocken, PA (US)
(72) Inventors: **Eric L. Canfield**, Exton, PA (US);
Thomas M. Dykstra, Alachua, FL (US);
Scott J. Soma, Media, PA (US); **Robert E. Rasmussen**, Coatesville, PA (US);
Robert P. Alston, Exton, PA (US)

(73) Assignee: **Technology SG, L.P.**, West
Conshohocken, PA (US)

(*) Notice: Subject to any disclaimer, the term of this patent is extended or adjusted under 35 U.S.C. 154(b) by 0 days.

(21) Appl. No.: **13/839,636**

(22) Filed: **Mar. 15, 2013**

(65) **Prior Publication Data**
US 2014/0259858 A1 Sep. 18, 2014

(51) **Int. Cl.**
A01M 1/04 (2006.01)
A01M 1/02 (2006.01)
A01M 29/10 (2011.01)
A01M 29/08 (2011.01)
A01M 31/06 (2006.01)

(52) **U.S. Cl.**
CPC . *A01M 1/04* (2013.01); *A01M 1/02* (2013.01);
A01M 31/06 (2013.01)
USPC 43/113; 43/107; 43/132.1; 250/495.1;
250/493.1; 250/503.1; 250/504 R

(58) **Field of Classification Search**
USPC 43/107, 113, 114, 132.1; 250/493.1,
250/494.1, 495.1, 503.1, 504 R, 505.1,
250/517.1

See application file for complete search history.

(56) **References Cited**

U.S. PATENT DOCUMENTS

1,819,551 A * 8/1931 Gourdon 43/113
2,059,835 A * 11/1936 Worthing et al. 43/132.1
2,645,877 A * 7/1953 Pohlman 43/113
2,731,762 A * 1/1956 Jones 43/113

(Continued)

FOREIGN PATENT DOCUMENTS

WO WO 98/10643 A1 3/1998
WO WO 9810643 A1 * 3/1998 A01M 1/04

(Continued)

OTHER PUBLICATIONS

Callahan, P.S., "A High Frequency Dielectric Waveguide on the Antennae of Night-Flying Moths (Saturniidae)," Applied Optics, vol. 7, No. 8, Aug. 1968; pp. 1425-1430.

(Continued)

Primary Examiner — Darren W Ark
(74) *Attorney, Agent, or Firm* — Sterne, Kessler, Goldstein & Fox P.L.L.C.

(57) **ABSTRACT**

An insect decoy is provided that includes a vapor-isolated vessel, a chemical compound disposed within the vapor-isolated vessel, and an excitation energy source. The chemical compound may have one or more absorption bands at a set of absorption wavelengths and have one or more emission bands at a set of emission wavelengths. The excitation energy source may be configured to produce electromagnetic radiation at the absorption wavelengths so as to fluoresce the chemical compound and release photons at the emission wavelengths. The vapor-isolated vessel may be configured with at least one infrared transmissive window that is substantially transparent to the released photons at the emission wavelengths of the chemical compound.

22 Claims, 4 Drawing Sheets

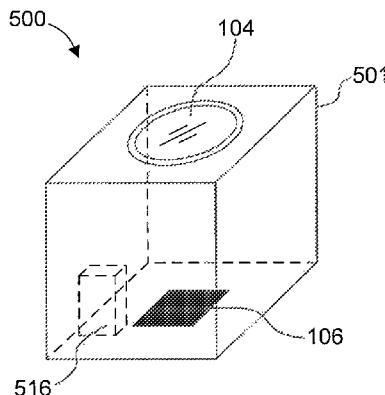

(56)

References Cited

FOREIGN PATENT DOCUMENTS

U.S. PATENT DOCUMENTS

3,653,145	A *	4/1972	Stout	43/131
3,997,785	A *	12/1976	Callahan	250/338.1
4,018,530	A *	4/1977	Hirschfeld	250/459.1
4,069,615	A *	1/1978	Gilbert	43/107
4,282,673	A *	8/1981	Focks et al.	43/113
4,411,093	A *	10/1983	Stout et al.	43/114
4,490,040	A *	12/1984	Lucht et al.	250/458.1
4,675,300	A *	6/1987	Zare et al.	204/452
4,982,100	A *	1/1991	Harding, Jr.	250/504 R
5,247,933	A	9/1993	Callahan et al.	
5,424,551	A *	6/1995	Callahan	43/113
5,528,049	A *	6/1996	Callahan	43/113
5,634,292	A *	6/1997	Kitterman	43/113
5,766,617	A *	6/1998	Heath et al.	424/410
5,801,828	A *	9/1998	Collins	250/461.1
5,896,695	A *	4/1999	Walker	43/113
5,921,018	A *	7/1999	Hirose et al.	43/132.1
6,088,949	A	7/2000	Nicosia et al.	
6,178,687	B1 *	1/2001	Frisch	43/114
6,199,315	B1 *	3/2001	Suzue et al.	43/113
6,298,011	B1	10/2001	Nyberg et al.	
6,301,194	B1	10/2001	Cauchy	
6,438,894	B1 *	8/2002	Silvandersson et al.	43/114
6,515,539	B1 *	2/2003	Levanon et al.	330/4
6,655,080	B2	12/2003	Spiro et al.	
6,662,489	B2	12/2003	Spiro et al.	
6,795,568	B1	9/2004	Christensen et al.	
6,928,769	B2 *	8/2005	Crawley et al.	43/107
6,965,205	B2 *	11/2005	Piepgas et al.	315/318
7,176,828	B2	2/2007	Tirkel et al.	
7,181,885	B2	2/2007	Spiro et al.	
7,286,056	B2 *	10/2007	Kates	250/221
7,368,743	B2 *	5/2008	Nichols	250/504 R
7,412,797	B1	8/2008	Hiscox	
7,415,313	B2	8/2008	Brueckner et al.	
7,541,936	B2 *	6/2009	Wijenberg et al.	43/113
7,599,731	B2 *	10/2009	Rice et al.	250/363.01
7,623,625	B2 *	11/2009	Boyden et al.	378/86
7,698,853	B2 *	4/2010	Ragon et al.	43/132.1
7,712,247	B2 *	5/2010	Wijenberg et al.	43/121
7,784,215	B2 *	8/2010	Cohnstaedt et al.	43/113
7,869,042	B2 *	1/2011	Aasmul	356/417
7,892,528	B2 *	2/2011	Siljander et al.	424/84
7,937,887	B2 *	5/2011	Child	43/113
8,111,164	B2	2/2012	Bryce	
8,211,419	B2 *	7/2012	Siljander et al.	424/84
8,893,428	B2 *	11/2014	Dykstra	43/120
2002/0125419	A1 *	9/2002	Callahan	250/251
2003/0151006	A1 *	8/2003	Dykstra	250/493.1
2003/0178616	A1	9/2003	Prevenslik	
2004/0115235	A1 *	6/2004	Simpson	424/416
2005/0212691	A1	9/2005	Tirkel et al.	
2007/0107297	A1	5/2007	Wijenberg et al.	
2007/0132598	A1	6/2007	Wijenberg et al.	
2008/0168703	A1	7/2008	Siljander et al.	
2008/0289246	A1 *	11/2008	van Bers	43/113
2009/0086894	A1 *	4/2009	Boyden et al.	250/310
2009/0288333	A1 *	11/2009	Johnston et al.	43/113
2010/0050499	A1	3/2010	Liang	
2010/0071257	A1 *	3/2010	Tsai	43/113
2011/0099886	A1	5/2011	Siljander et al.	
2011/0101252	A1 *	5/2011	Rubochkin	250/504 R
2011/0136154	A1 *	6/2011	Geddes	250/458.1
2011/0296740	A1 *	12/2011	Yamada et al.	43/113
2012/0032096	A1 *	2/2012	Marka et al.	250/492.1
2012/0061590	A1 *	3/2012	Khojasteh et al.	250/459.1
2012/0204475	A1	8/2012	Schneidmiller et al.	
2012/0315666	A1 *	12/2012	Fujioka et al.	250/458.1
2013/0283671	A1 *	10/2013	Czokajlo et al.	43/113
2014/0197335	A1 *	7/2014	Jayasooriya et al.	250/459.1

WO	WO 2008088546	A2 *	7/2008	A01M 1/02
WO	WO 2012010238	A1 *	1/2012	A61N 5/06

OTHER PUBLICATIONS

- Callahan, P.S., "Comments on Mark Diesendorf's Critique of My Review Paper," *International Journal of Insect Morphology and Embryology*, vol. 6, No. 2, 1977; pp. 111-122.
- Callahan, P.S., "Insect Antennae with Special Reference to the Mechanism of Scent Detection and the Evolution of the Sensilla," *International Journal of Insect Morphology & Embryology*, vol. 4, No. 5, 1975; pp. 381-430.
- Callahan, P.S., "Insect Molecular Bioelectronics: A Theoretical and Experimental Study of Insect Sensillae as Tubular Waveguides, with Particular Emphasis on Their Dielectric and Thermoelectric Properties," *Miscellaneous Publications of the Entomological Society of America*, vol. 5, No. 7, 1967; pp. 315-347.
- Callahan, P.S., "Intermediate and Far Infrared Sensing of Nocturnal Insects. Part I. Evidences for Far Infrared (FIR) Electromagnetic Theory of Communication and Sensing in Moths and Its Relationship to the Limiting Biosphere of the Corn Earworm," *Annals of the Entomological Society of America*, vol. 58, No. 5, Sep. 1965; pp. 727-745.
- Callahan, P.S., "Moth and candle: the candle flame as a sexual mimic of the coded infrared wavelengths from a moth sex scent (pheromone)," *Applied Optics*, vol. 16, No. 12, Dec. 1977; pp. 3089-3097.
- Callahan, P.S., et al., "The Scape and Pedicel Dome Sensors—A Dielectric Aerial Waveguide on the Antennae of Night-Flying Moths," *Annals of the Entomological Society of America*, vol. 61, No. 4, Jul. 1968; pp. 934-937.
- Diesendorf, M., et al., "A theoretical investigation of radiation mechanisms of insect chemoreception," *Proceedings of the Royal Society of London, Series B*, vol. 185, 1974; pp. 33-49.
- Diesendorf, M., "Insect Sensilla as Dielectric Aerials for Scent Detection: Comments on a Review by Callahan," *CSIRO, Division of Mathematics and Statistics, International Journal of Insect Morphology & Embryology*, vol. 6, No. 2, 1977; 12 pages.
- Diesendorf, M., "The 'Dielectric Waveguide Theory' of Insect Olfaction: A Reply to P.S. Callahan," *International Journal of Insect Morphology and Embryology*, vol. 6, No. 2, 1977 pp. 123-126.
- Fabre, J.-H., "Social Life in the Insect World," 1st Edition published 1911, e-Book released May 8, 2006; 136 pages.
- Laithwaite, E.R., "A Radiation Theory of the Assembling of Moths," *The Entomologist*, vol. 93, No. 1165, Jun. 1960; pp. 1-5.
- Lakowicz, J.R., "Principles of Fluorescence Spectroscopy," 3rd Edition, 2006; pp. 32 and 74-75.
- Millar, J.G., et al., "Evaluation of Release Rates of Codling Moth Pheromone Mating Disruption Dispensers," 1995; pp. 167-170.
- Prevenslik, T., "Odorant molecules signal the G-protein receptors with their unique IR spectra," *PRLog*, Sep. 26, 2010; 3 pages.
- Prevenslik, T., "Olfaction and Far Infrared Signaling by Moths," *QED Radiations Discovery Bay*, 2011; 3 pages.
- Smith, F.G., "The Infrared and Electro-Optical Systems Handbook, vol. 2: Atmospheric Propagation of Radiation," *The Society of Photo-Optical Instrumentation Engineers*, 1993; 333 pages.
- Sower, L.L., et al., "Rate of Release of Sex Pheromone of the Female Indian Meal Moth," *Environmental Entomology*, vol. 4, No. 1, Feb. 1975; pp. 168-169.
- Suh, C., et al., "Profile of Pheromone Released from Hercon, Plato, and Scentry Lures," *TAC Meeting, USDA Agricultural Research Service* Feb. 14-15, 2011; 14 pages.
- Trails, R.R., "How Popperian positivism killed a good-but-poorly-presented theory—Insect Communication by Infrared," *Ondwelle Short-Monograph*, No. 3, 2005; pp. 1-24.
- Zissis, G.J., "The Infrared and Electro-Optical Systems Handbook, vol. 1: Sources of Radiation," *The Society of Photo-Optical Instrumentation Engineers*, 1993; 383 pages.
- Callahan, P.S., "Tuning in to Nature: Infrared Radiation and the Insect Communication System," 25th Anniversary Edition, *Acres U.S.A., Publishers* (2001).

(56)

References Cited

OTHER PUBLICATIONS

International Search Report and Written Opinion directed to related

International Patent Application No. PCT/US14/23480, mailed Jul. 8, 2014; 16 pages.

* cited by examiner

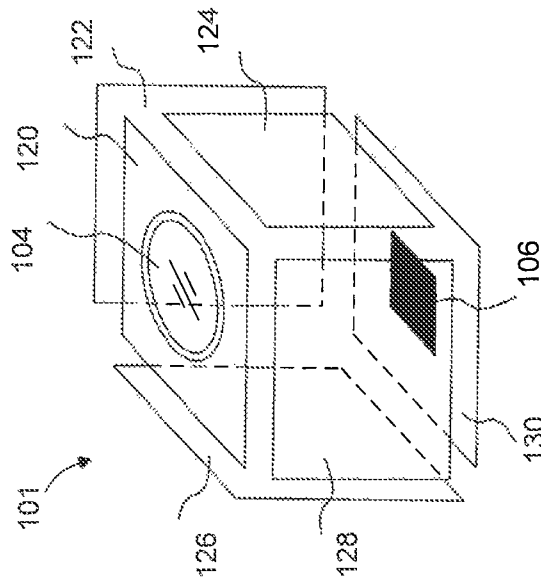

FIG. 1B

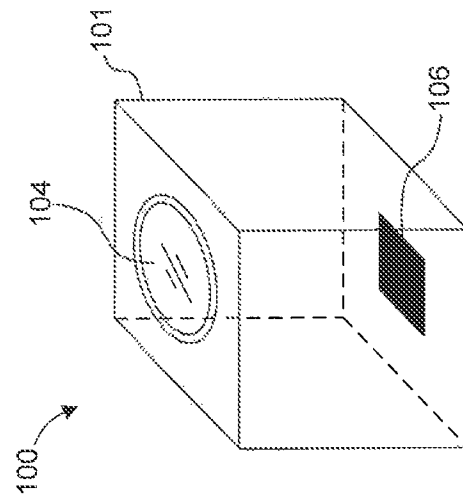

FIG. 1A

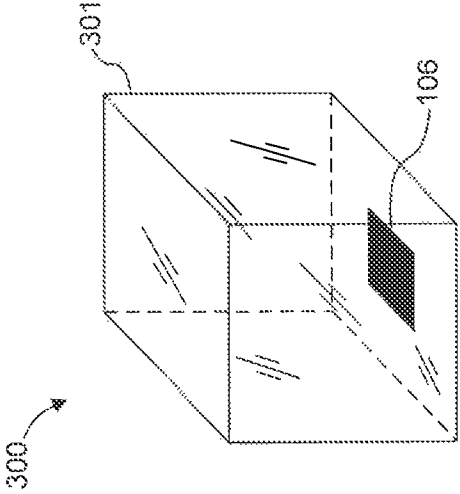

FIG. 2

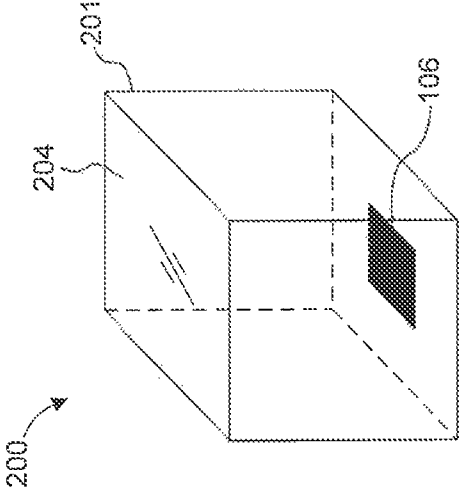

FIG. 3

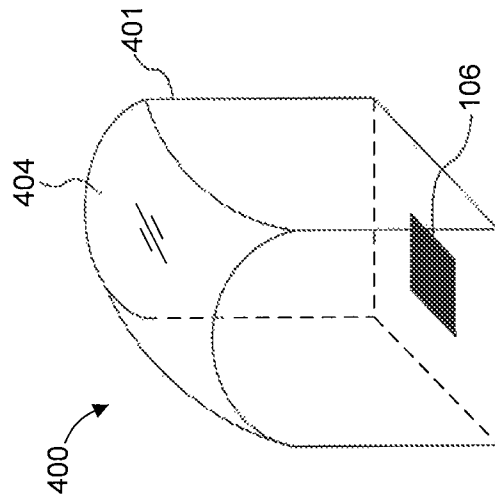

FIG. 4

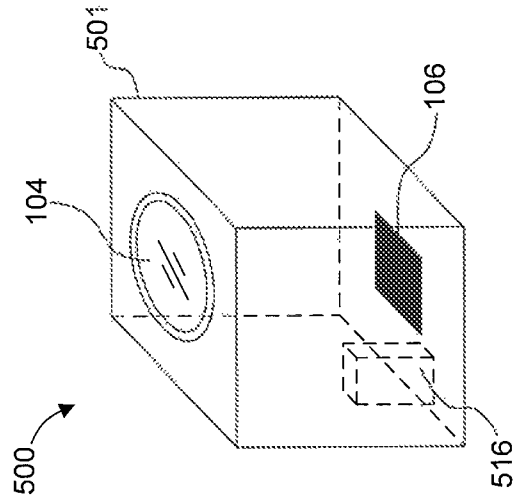

FIG. 5

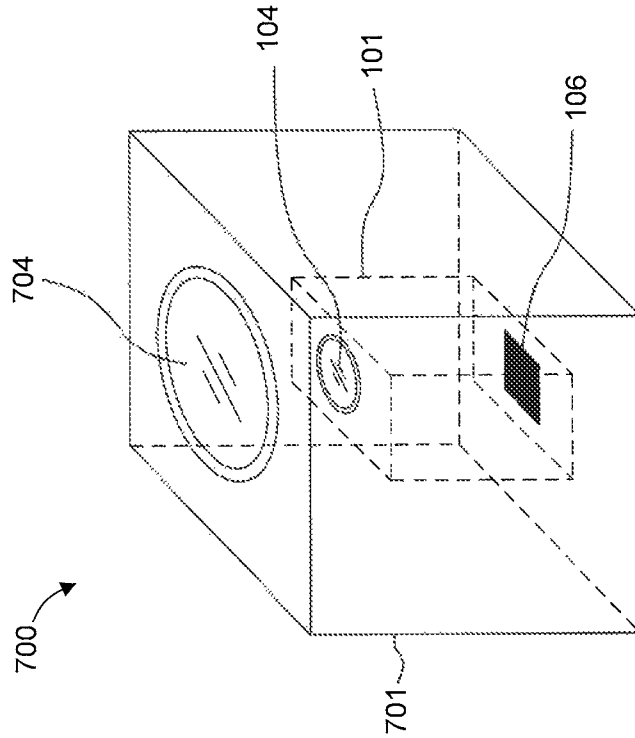

FIG. 6

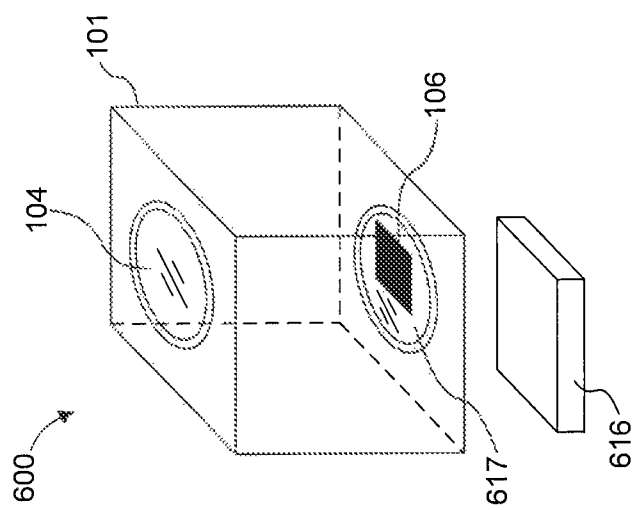

FIG. 7

1

RADIATING SYSTEMS FOR AFFECTING INSECT BEHAVIOR

FIELD

Embodiments of the present invention are directed to elec-
tromagnetic radiation systems for affecting insect behavior.

BACKGROUND

Integrated Pest Management, or IPM, for the US Depart-
ment of Agriculture's estimated 913 million farmed acres, the
more than 7 billion bushels of stored grain, and the 100
million metric tons of exported agricultural products is a
multi-billion dollar industry in the United States. The world-
wide problem of pest management is much larger.

Stored grain is transported all over the world by ship, truck,
and plane. The distribution of grain is dependent on short to
long-term storage ranging from a few days to more than a
year. The long-term storage of grain has encouraged the expo-
nential growth of many insects and other pests that infest
stored grain. One example pest is the Indian meal moth.
Augmentation of pest populations are facilitated by the vir-
tually unlimited food source found in storage grain bins or
warehouses. Estimated losses caused by pests in temperate
climates come to approximately 10-15%, but in tropical
countries, the figure can be as high as 60%.

In less severe cases, unhealthy insect infestations, while
not directly consuming the grain in bulk, greatly reduce mar-
ketability simply by their presence. Insect body parts or resi-
dues that can be found in storage grain samples thus create
financial hardship for many farmers. On a state level, this
monetary figure runs into the hundreds of millions of dollars,
but nationally, it is in the billions.

Farmers and industry have turned to chemical management
in the form of pesticides and insecticides in an effort to reduce
the pest populations found in stored grains and invading farm-
land. Several problems are associated with the chemical man-
agement of pest infested stored grains and the spraying of
insecticides over millions of acres of crops. These problems
include chemical residues being left on grain destined for
human or animal consumption, accidental human exposure to
fumigants resulting in death or sickness, corrosive damage to
sensitive equipment such as computers, and the potentially
high financial costs of fumigation, most especially at ports.
These are serious problems that all present and future fumi-
gation companies must address. Further, the ongoing research
and development of even more potent and potentially toxic
pesticides continues because insects are robust in their ability
to develop immunity over time to those chemicals designed
specifically to control their populations. Simply stated, the
chemicals that work to reduce insect populations today will
likely be ineffective in the future due to the insects developing
resistance to the same.

An alternative to chemical management is the use of insect
traps that contain artificially produced molecules called
pheromones. These artificial pheromones may also be
deployed in agriculture in order to confuse the insects or
disrupt mating. Typically in nature, these molecules are
released into the atmosphere by the insects and are used to
locate a mate or to aggregate. Current pheromone traps have
many limitations. One limitation includes the relatively small
number of insects trapped over a given period of time relative
to the actual insect population. There are no reliable figures to
specify the percentage of insects that can be successively
trapped in a given area. Therefore, the traps are more fre-
quently used to simply determine the presence of a given

2

insect population so that some other method of population
control can be deployed, which is usually insecticidal in
nature. As a result, years of research wholly supports that the
traps are ineffective at significantly reducing insect popula-
tions in a storage grain bin or warehouse unless the traps are
used in very high densities. With respect to aerosol or lure
deployment for agricultural control of insects on farmland, it
is an expensive proposition with numerous limitations.
Inclement weather, high winds, and other factors all contrib-
ute to this type of deployment often not even being considered
as a solution.

A second limitation is the reduced longevity of the phero-
mone source or lure in conventional traps, aerosols, or lures.
The longevity of the typical pheromone lure is estimated to be
approximately six weeks, based on written information pro-
vided by the pheromone manufacturers.

BRIEF SUMMARY

Consequently, a system is provided herein to solve the
above-identified problems without the harmful side-effects of
chemical management.

In an embodiment of the present invention, an insect decoy
is provided that includes a vapor-isolated vessel, a chemical
compound disposed within the vapor-isolated vessel, and a
naturally occurring or artificially produced excitation energy
source. The chemical compound may have one or more
absorption bands at a set of absorption wavelengths and have
one or more emission bands at a set of emission wavelengths.
The excitation energy source may be configured to produce
electromagnetic radiation at the absorption wavelengths so as
to fluoresce the chemical compound and release photons at
the emission wavelengths. The vapor-isolated vessel may be
configured with at least one infrared transmissive window
that is substantially transparent to the released photons at the
emission wavelengths of the chemical compound.

In another embodiment of the present invention, an insect
trap is provided that includes an outer vessel and a closed,
vapor-isolated inner vessel within the outer vessel. The outer
vessel may include a housing and at least one infrared trans-
missive window. The housing may include an opening con-
figured to allow one or more insects to enter the outer vessel
while preventing the one or more insects from exiting the
outer vessel. The closed, vapor-isolated inner vessel may
include at least one infrared transmissive window aligned
with the infrared transmissive window in the outer vessel and
a chemical compound disposed within the vapor-isolated
inner vessel. The chemical compound may have one or more
absorption bands at a set of absorption wavelengths and have
one or more emission bands at a set of emission wavelengths.
The infrared transmissive window is substantially transparent
to electromagnetic radiation at the absorption wavelengths
and electromagnetic radiation at the emission wavelengths of
the chemical compound. The chemical compound releases
photons at the emission wavelengths when electromagnetic
radiation at the absorption wavelengths is received by the
chemical compound.

Further features and advantages, as well as the structure
and operation, of various embodiments of the present inven-
tion are described in detail below with reference to the accom-
panying drawings. It is noted that the present invention is not
limited to the specific embodiments described herein. Such
embodiments are presented herein for illustrative purposes
only. Additional embodiments will be apparent to persons
skilled in the relevant art(s) based on the teachings contained
herein.

BRIEF DESCRIPTION OF THE
DRAWINGS/FIGURES

The accompanying drawings, which are incorporated herein and form part of the specification, illustrate the present invention and, together with the description, further serve to explain the principles of the invention and to enable a person skilled in the pertinent art to make and use the invention. In the drawings, like reference numbers indicate identical or functionally similar elements. Additionally, the leftmost digit(s) of a reference number identifies the drawing in which the reference number first appears.

FIG. 1A illustrates an insect decoy system according to an embodiment of the present invention.

FIG. 1B illustrates an exploded view of the insect decoy system of FIG. 1.

FIG. 2 illustrates an insect decoy system according to another embodiment of the present invention.

FIG. 3 illustrates an insect decoy system according to another embodiment of the present invention.

FIG. 4 illustrates an insect decoy system according to another embodiment of the present invention.

FIG. 5 illustrates an insect decoy system including an internal excitation energy source according to an embodiment of the present invention.

FIG. 6 illustrates an insect decoy system including an external excitation energy source according to an embodiment of the present invention.

FIG. 7 illustrates an insect trap system according to an embodiment of the present invention.

The features and advantages of the present invention will become more apparent from the detailed description set forth below when taken in conjunction with the drawings.

DETAILED DESCRIPTION

Embodiments of the present invention provide a radiating insect decoy system for inducing behavioral changes in various types of insects. Inducing behavioral changes may be in the form of producing attractive, repulsive, or chaotic movement responses in various insects with respect to the embodiments of the present invention.

FIG. 1A illustrates an insect decoy system **100** according to an embodiment of the present invention. System **100** includes a vapor-isolated vessel **101**. Vapor-isolated vessel **101** may include a window **104**, and a chemical compound **106**. Vessel **101** may include sides **120**, **122**, **124**, **126**, **128**, and **130**, as illustrated in FIG. 1B in an exploded view of system **100**. Vapor-isolation may be provided, for example, by hermetically sealing vessel **101** or by placing vessel **101** under vacuum. As used herein, the term "vapor-isolated" does not require 100% vapor isolation. A vapor-isolated vessel may be substantially vapor-isolated, such as 90-95% vapor-isolated if, for example, sides **120**, **122**, **124**, **126**, **128**, or **130** exhibit some degree of vapor porosity. 100% vapor isolation is referred to herein as "completely vapor-isolated." Vessel **101** may be configured to be weather resistant and capable of being mounted or portably deployed in agricultural and stored grain environments.

In one example of this embodiment, chemical compound **106** emits infrared electromagnetic radiation by means of fluorescence. Fluorescence occurs when energy (e.g., light) from an excitation energy source is absorbed by a body (or molecule) at one or more frequency range(s) and is re-emitted at one or more different frequency ranges. The photonic emission is generally of a longer wavelength than the excitation source.

An absorption spectrum of a body is a plot of the absorption intensity of the fraction of incident radiation absorbed by that body as a function of wavelengths covering the electronic energy levels of the molecules in the body. While absorption spectra can be recorded for any absorbing material, excitation spectra can be recorded only for fluorescent materials apart from their usual absorption spectra.

For fluorescent materials, there are two types of spectra, namely, fluorescence emission spectra and excitation spectra. Emission spectra can be recorded by fixing an excitation wavelength at a particular wavelength, while intensity of emission wavelengths is scanned. The recorded emission wavelengths are obtained due to radiative relaxations of molecules from a higher energy level to which molecules are excited with energy at the fixed excitation wavelength to various lower energy levels. In an opposite manner, excitation spectra can be recorded by scanning intensity of excitation wavelengths while an emission wavelength is kept constant. In other words, an excitation spectrum will provide all the wavelengths absorbed by molecule that will result in a particular emission wavelength. All the excitation spectra corresponding to all the emission wavelengths can provide a spectrum which is almost the same as the absorption spectrum, but which differs somewhat since a signature of absorption is not obtained if that absorption does not yield fluorescence emission.

Chemical compound **106** may be characterized as having one or more absorption bands at different absorption wavelengths and one or more emission bands at different emission wavelengths.

As will be discussed in further detail below, the behavior of different types of insects may be affected by different emission wavelengths. These different wavelengths may include different fluorescence wavelengths of the same chemical compound, or the different wavelengths may include fluorescence wavelengths of multiple chemical compounds. Therefore, one chemical compound **106** may be used as an attractant, repellent, or disruptive agent for different types of insects. One or more chemical compounds **106** with different absorption and emission bands may be used in decoy system **100** to target different types of insects.

Chemical compound **106**, in an example embodiment, may include pheromone molecules. The fluorescence characteristics of the pheromone molecules results in the emission of electromagnetic radiation at various wavelengths in the infrared spectrum, referred to herein as the emission wavelengths. These wavelengths may be detected by insects and cause a change in their behavior. If an insect is sensitive to the emission wavelengths, such as those insects targeted by a specific pheromone, there are several types of behavior that may result from the insect's exposure to the emission wavelengths. A first type of behavior is an attraction behavior. If the emission wavelengths correspond to those produced by a sex or aggregation pheromone, an insect that detects the emission wavelengths may be attracted or lured to the pheromone as if it were a mating signal or a call to aggregate, respectively. A second type of behavior is a repelling behavior. If the emission wavelengths are too strong or are representative of something the insect would perceive as a threat, an insect may be overwhelmed and repelled by the signal, or seek evasive action or cover in the event of a perceived threat. A third type of behavior is confusion or chaotic response, which results when the emission wavelengths disrupt the insect from its normal behavior. Tests have shown that when some insects are exposed to certain emission wavelengths, their behavior is disrupted. The insects may, for example, become abnormally active, using up their own energy resources such that they are

unable to properly mate, or such that they die sooner than expected. The depletion of their energy resources may also produce unhealthy offspring, eventually resulting in an overall reduction in the insect population.

The infrared fluorescence of the pheromone molecules allows the use of pheromone molecules even though they are housed in vapor-isolated vessel **101**. In fact, the vapor-isolation of the pheromone molecules in vessel **101** may enable greater longevity of the molecules than the current methods used for deployment, including traps and aerosols, which diffuse pheromone molecules into open space. Dissipation, spreading, diffusion, or releasing of pheromone molecules into the open environment can cause a decline in parts-per-million concentration and radiation release rates as a function of time, such that their effectiveness in prompting insect behavior is also reduced.

In an example embodiment, chemical compound **106** is deposited on or adhered to a single one of sides **120**, **122**, **124**, **126**, **128**, and **130**. In another example embodiment, chemical compound **106** is deposited onto a plurality of interior sides of vessel **101**. Each side of vessel **101** may have deposited the same or a different chemical compound. As mentioned above, different types of chemical compounds may be used to enable decoy system **100** to affect behavior in a variety of insects. In another example of this embodiment, chemical compound **106** may be deposited or adhered onto one or more substrates placed in vessel **101**, instead of being deposited directly onto a side of vessel **101**. Other mechanisms, methodologies, and techniques can be employed to introduce chemical compound **106** into vessel **101**, and are deemed to be within the scope of the present invention.

The chemical compound may be in liquid, gaseous, or solid form. For example, the chemical compound may be a gas or liquid that fills a separate vial located within vessel **101**, said vial being transmissive to the absorption and emission wavelengths of interest specific to the chemical compound. In another example, the gas may be inserted directly into vessel **101**, such that it disperses throughout vessel **101**. In another example, the chemical compound is a liquid or solid disposed on an interior surface of vessel **101** or a surface of a separate substrate, which substrate is then placed within vessel **101**. Any other number of mechanisms may be employed to contain the chemical compound in insect decoy system **100**.

FIGS. **1A** and **1B** show vessel **101** as a cuboid shape having sides **120**, **122**, **124**, **126**, **128**, and **130**, according to an example embodiment. However, vessel **101** is not restricted to being cuboid in shape or having other straight-sided shapes. Vessel **101** may be configured to be any type of geometric shape, such as but not limited to cylindrical, spherical, or elliptical. Vessel **101** may be constructed from a variety of materials that are configured to prevent substantial penetration of vapor or electromagnetic radiation from chemical compound **106** through sides **120**, **122**, **124**, **126**, **128**, and **130**. Alternatively, one or more sides may be made of a material that prevents substantial penetration of vapor, but which is transmissive to electromagnetic radiation at the absorption and/or emission wavelengths. Vessel **101** materials may include natural or synthetic materials, such as but not limited to metals, non-metals, and/or alloys. For example, vessel **101** may be made from, for example and without limitation, high density polyethylene (HDPE) or low-density polyethylene (LDPE). Such materials may have transmissivity through 20 microns, for example, to allow passage of infrared radiation while restricting other types of electromagnetic radiation.

In one example of this embodiment, the inner surface of one or more sides of vessel **101** may be partially or fully

covered with a reflective surface. In an embodiment, chemical compound **106** may be deposited on or adhered to one or more sides having reflective surfaces. A reflective surface may include a mirror or like material that prevents, for example, absorption of radiation from chemical compound **106** or passing of radiation from chemical compound **106** through vessel **101**. The surface may be, for example, a first surface mirror. The reflective surface may be reflective to electromagnetic radiation at wavelengths of the absorption band, emission band, or both the absorption and emission bands of chemical compound **106**, according to examples of this embodiment.

Window **104** may be transmissive to infrared radiation according to an example embodiment. Window **104** may be transmissive specifically to wavelengths in the emission bands of chemical compound **106**. Window **104** may also be transmissive to wavelengths in the absorption bands of chemical compound **106**. Infrared transmissive window **104** may be slightly porous, thereby making vessel **101** less than 100% vapor-isolated. For example, infrared transmissive window **104** may be made from a material that is approximately 5% porous (95% vapor-isolated). HDPE is one such material.

As illustrated in FIG. **1A**, window **104** may be strategically positioned to allow emission of electromagnetic radiation from chemical compound **106** through window **104**. Although window **104** is illustrated as being located on top of vessel **101**, window **104** may additionally or alternatively be located at other sides of vessel **101**, as long as emission of radiation from chemical compound **106** can be released into the environment external to vessel **101**.

FIGS. **1A** and **1B** illustrate vessel **101** having a window **104** of a circular shape. However, vessel **101** may include windows in various shapes and sizes. As shown in FIG. **2**, vessel **201** of insect decoy system **200** may include a rectangular shaped window **204** that forms a side of vessel **201**, according to an embodiment of the present invention. Window **204** may have similar transmissive properties as window **104**. Yet in another embodiment, vessel **201** may include a plurality of windows with transmissive properties similar to windows **104** and **204**. The plurality of windows may form a vessel **301**, as illustrated in FIG. **3**. Even though FIG. **3** illustrates insect decoy system **300** as a vessel **301** having a substantially flat, straight-sided window on each side, a window of vessel **301** may take any geometric shape, such as but not limited to cylindrical, spherical, or elliptical.

In embodiments, window **104** may be directional or omnidirectional. As further illustrated in FIG. **4**, according to an embodiment, vessel **401** of insect decoy system **400** may include a lens, such as a concave lens, as window **404**. Window **404** may be capable of focusing infrared radiation emitted by chemical compound **106**. In an embodiment, directionality may be additionally or alternatively facilitated with an internal or external reflector (not shown).

According to another embodiment of the present invention, FIG. **5** illustrates an insect decoy system **500**. Insect decoy system **500** is similar to insect decoy system **100** of FIG. **1**, but includes an excitation energy source **516** within vapor-isolated vessel **501**. Excitation energy source **516** may be an isolated system located within vessel **501**, or it may be an integrated part of vessel **501**. Examples of excitation energy source elements include, without limitation, heating elements, capacitive elements, and solar energy elements. If the excitation energy source is an integrated part of vessel **501**, then excitation energy source **516** is a part of vessel **501**. In an embodiment, excitation energy source **516** is integrated into one or more sides of vessel **501**. For example, a side of vessel

501 may be made of a dielectric material that builds up energy as a capacitive charge. This energy can then be transferred to chemical compound **106**.

Excitation energy source **516** may be configured to produce electromagnetic radiation in the absorption bands of chemical compound **106**. Exciting chemical compound **106** with radiation produced by excitation energy source **516** may result in the fluorescence of compound **106**. This fluorescence releases photons having wavelengths in the emission bands of compound **106**. The electromagnetic radiation from excitation energy source **516** may be produced by various means, such as but not limited to thermal, electrical, or optical, according to various embodiments. In an embodiment, excitation energy source **516** is configured to modulate the electromagnetic radiation. Such modulation may be electrically or manually induced, depending on, for example, whether the excitation energy source is actively produced, naturally occurring, or a function of re-radiation. Increasing the amount of fluorescing energy that acts upon chemical compound **106**, using excitation energy source **516**, may increase the emission of radiation from chemical compound **106**, which in turn may increase the corresponding volumetric area in which insects' behavior may be affected. The greater the infrared emission from chemical compound **106**, the more likely the insect will be able to detect and react to the emission.

In another example of this embodiment, the infrared emission from chemical compound **106** may be increased, for example, by increasing the amount of chemical compound **106** in vessels **101**, **201**, **301**, **401**, or **501**.

The desired level of emission radiation is a function of the amount of the chemical compound and the amount of energy provided by the excitation energy source, taking into consideration variables such as the cost of the chemical compound, the desired volumetric size of the effective area, and efficiency of the excitation energy source, among other things.

According to another embodiment of the present invention, FIG. 6 illustrates an insect decoy system **600**. Insect decoy system **600** is similar to insect decoy system **100** of FIG. 1, but includes an additional window **617** in vessel **101** and an excitation energy source **616** located external to vapor-isolated vessel **101**. Excitation energy source **616** may be configured to perform similar functions as excitation energy source **516**. Window **617** may be transmissive to wavelengths produced by excitation energy source **616**. In an embodiment, window **617** may be placed strategically with respect to excitation energy source **616** and chemical compound **106** to allow radiation from excitation energy source **616** to enter vessel **101** and excite chemical compound **106**. As discussed above, excitation of chemical compound **106** with excitation energy source **616** may result in chemical compound **106** fluorescing radiation at wavelengths in the infrared spectrum, which are then released through window **104**. Insects responsive to or influenced by radiation from chemical compound **106** may be attracted, repelled, or confused depending on the fluorescing wavelength, depending on the intensity of the radiation emitting from compound **106**.

In an embodiment, the window allowing radiation from excitation energy source **616** to enter vessel **101** is the same window that allows radiation emitted by the chemical compound to exit vessel **101**.

For the sake of simplicity, FIG. 6 illustrates insect decoy system **600** having one substantially flat and straight-sided window **617** that may be transmissive to radiation from an external excitation energy source. However, system **600** may have windows in varying numbers and in varying shapes that are similar to window **617** in their transmissive properties.

Windows **104** and **617** of system **600** may be placed in different orientations with respect to each other and may not necessarily be placed as illustrated in FIG. 6. In an embodiment, vessel **101** of system **600** may have windows transmissive to both wavelengths entering vessel **101** from excitation energy source **616** and leaving vessel **101** from chemical compound **106**.

FIG. 7 illustrates an insect trap system **700** comprising an insect decoy system **100** and an insect trap vessel **701**, according to an embodiment of the present invention. Insect trap vessel **701** includes an aperture **704**. In an embodiment, insect decoy system **100** may be enclosed within trap vessel **701**. System **100** may be strategically positioned in trap vessel **701** such that window **104** and aperture **704** are optically aligned. This optical alignment may enable infrared radiation from chemical compound **106** to exit insect trap system **700** through window **104** and aperture **704** to the surrounding environment. Trap vessel **701** may be configured similarly to vessel **101** as previously discussed. That is, trap vessel **701** may be impermeable to radiation from chemical compound **106**. In that case, trap system **700** may not be effective without optical alignment of window **104** and aperture **704**. When window **104** and aperture **704** are aligned, the released radiation from chemical compound **106** may attract insects into trap system **700** through aperture **704**.

In an example embodiment, aperture **704** is a circular opening on a side of trap vessel **701**, as illustrated in FIG. 7. The diameter of aperture **704** may be varied to adjust for insect size and may be designed to allow for insect entry while prohibiting insect escape once inside trap vessel **701**, as is common in the art. Although aperture **704** is illustrated as being circular, aperture **704** may form other geometric shapes, or may be located at other positions, such as on sides of trap vessel **701**.

In another example of this embodiment, aperture **704** may be attached to a barrier (not shown) that permits insects attracted by the emission from chemical compound **106** to enter aperture **704**, but may prevent insects from escaping trap vessel **701**. Aperture **704** may be, for example, a one-way bristle-type opening. Multiple apertures similar to aperture **704** may be strategically formed in trap vessel **701**. A sticky substance may be disposed inside of trap vessel **701** that may prevent trapped insects from exiting trap vessel **701**.

In another embodiment, insect decoy system **100** may be located near, but external to, trap vessel **701**.

In yet another embodiment, insect decoy system **100** may be located within a screen mesh forming an enclosed trap that allows the released radiation from chemical compound **106** to pass through the screen, the screen mesh further allowing insects to enter but not escape.

In yet another embodiment, insect decoy system **100** may be located in near proximity to an electrostatic device that stuns or kills the insect.

According to other embodiments of the present invention, insect trap systems may be configured by integrating trap vessel **701** with other insect decoy systems, such as but not limited to systems **500** and **600** as described above. Trap vessel **701** may be configured to enclose systems **500** and **600** in a manner as illustrated for system **100** in FIG. 7.

One example structure, in accordance with an embodiment of the present invention, uses solar radiation-absorptive materials that nocturnally reradiate, serving as an excitation energy source. In one embodiment and by way of example, two intersecting triangles of solar radiation-absorptive materials may be combined to form a tent-like structure. This tent-like structure of re-radiating material constitutes the excitation energy source of the insect decoy system. A vapor-

isolated vessel containing the chemical compound of interest is disposed in the interior of the tent-like structure. A vessel wall surrounding the excitation energy source is made from flexible LDPE or HDPE material. The vessel wall is doped with adhesive bands to capture insects attracted to the chamber.

While various embodiments of the present invention have been described above, it should be understood that they have been presented by way of example, and not limitation. It will be apparent to persons skilled in the relevant art(s) that various changes in form and detail can be made therein without departing from the spirit and scope of the invention. Thus, the present invention should not be limited by any of the above described exemplary embodiments, but should be defined only in accordance with the following claims and their equivalents.

What is claimed is:

1. An insect decoy, comprising:
 - a vapor-isolated vessel having at least one infrared transmissive window, wherein the vapor-isolated vessel is at least 90% vapor-isolated;
 - a chemical compound disposed within the vessel, the chemical compound having one or more absorption bands at a set of absorption wavelengths and having one or more emission bands at a set of emission wavelengths; and
 - an excitation energy source, the excitation energy source configured to produce electromagnetic radiation at the absorption wavelengths so as to fluoresce the chemical compound and release photons at the emission wavelengths, wherein the at least one infrared transmissive window is substantially transparent to the released photons at the emission wavelengths.
2. The insect decoy of claim 1, wherein the excitation energy source is disposed within the vessel.
3. The insect decoy of claim 1, wherein, the excitation energy source is disposed outside the vessel.
4. The insect decoy of claim 1, wherein the at least one infrared transmissive window is also substantially transparent to the absorption wavelengths.
5. The insect decoy of claim 1, wherein the chemical compound is a pheromone specific to a given type of insect.

6. The insect decoy of claim 1, wherein the vapor-isolated vessel is 100% vapor-isolated.

7. The insect decoy of claim 1, wherein the vapor-isolated vessel is less than 100% vapor-isolated.

8. The insect decoy of claim 1, wherein the vapor-isolated vessel comprises at least one internal reflective surface.

9. The insect decoy of claim 8, wherein the chemical compound is adhered to the at least one internal reflective surface.

10. The insect decoy of claim 8, wherein the at least one internal reflective surface is reflective to electromagnetic radiation at the absorption wavelengths.

11. The insect decoy of claim 8, wherein the at least one internal reflective surface is reflective to electromagnetic radiation at the emission wavelengths.

12. The insect decoy of claim 8, wherein the at least one internal reflective surface is reflective to electromagnetic radiation at both the absorption wavelengths and the emission wavelengths.

13. The insect decoy of claim 1, wherein the excitation energy source comprises an active electromagnetic radiator.

14. The insect decoy of claim 13, wherein the excitation energy source is configured to be modulated.

15. The insect decoy of claim 1, wherein the at least one infrared transmissive window is directional.

16. The insect decoy of claim 1, wherein the at least one infrared transmissive window is omnidirectional.

17. The insect decoy of claim 1, wherein the at least one infrared transmissive window is a lens.

18. The insect decoy of claim 1, wherein electromagnetic radiation at the emission wavelengths attracts a given type of insect.

19. The insect decoy of claim 1, wherein electromagnetic radiation at the emission wavelengths repels a given type of insect.

20. The insect decoy of claim 1, wherein electromagnetic radiation at the emission wavelengths invokes a chaotic response in a given type of insect.

21. The insect decoy of claim 1, further comprising a trap configured to hold one or more insects.

22. The insect decoy of claim 1, wherein the vapor-isolated vessel is at least 95% vapor-isolated.

* * * * *