

(12) **United States Patent**
Canfield et al.

(10) **Patent No.:** **US 10,969,292 B2**
(45) **Date of Patent:** **Apr. 6, 2021**

- (54) **APPARATUS FOR MEASURING IMBALANCE FORCES OF A TIRE/HUB ASSEMBLY OF A VEHICLE DURING MOTION OF THE VEHICLE**
- (71) Applicant: **BALANCED ENGINEERING SOLUTION, LLC**, Towson, MD (US)
- (72) Inventors: **Eric L. Canfield**, Downingtown, PA (US); **David M. Scribner**, Cocoa Beach, FL (US); **Scott J. Soma**, Media, PA (US); **Robert P. Alston**, Exton, PA (US); **David Fenimore**, Coatesville, PA (US); **Zoe Kane**, Greer, SC (US); **Rachel Foster**, Coatesville, PA (US); **Meer Gujral**, Chester Springs, PA (US); **Joseph H. Cottingham**, Downingtown, PA (US); **Saahas S. Yechuri**, Downingtown, PA (US); **Aron Sun**, Exton, PA (US); **Ethan Reiland**, Downingtown, PA (US); **Anish Sudini**, Exton, PA (US); **Amish Saini**, Exton, PA (US); **William Liao**, Downingtown, PA (US); **Rohan Epur**, Chester Springs, PA (US); **Ryan M. Larue**, Coatesville, PA (US); **Brandon T. Fanti**, Coatesville, PA (US)
- (73) Assignee: **BALANCED ENGINEERING SOLUTION, LLC**, Towson, MD (US)
- (*) Notice: Subject to any disclaimer, the term of this patent is extended or adjusted under 35 U.S.C. 154(b) by 102 days.

(21) Appl. No.: **16/557,154**

(22) Filed: **Aug. 30, 2019**

(65) **Prior Publication Data**
US 2021/0063267 A1 Mar. 4, 2021

(51) **Int. Cl.**
G01M 1/28 (2006.01)
G01M 17/02 (2006.01)

(52) **U.S. Cl.**
CPC **G01M 1/28** (2013.01); **G01M 17/022** (2013.01)

(58) **Field of Classification Search**
None
See application file for complete search history.

(56) **References Cited**
U.S. PATENT DOCUMENTS
3,888,128 A 6/1975 Mitchell
5,443,537 A * 8/1995 Haskins G01B 11/275 33/193
(Continued)

OTHER PUBLICATIONS
Beeline, on vehicle wheel balancing, www.beeline-co.com/products/wheel-balancing (Year: 2021),*
(Continued)

Primary Examiner — Gregory J Toatley, Jr.
Assistant Examiner — Denise R Karavias
(74) *Attorney, Agent, or Firm* — Panitch Schwarze Belisario & Nadel LLP

(57) **ABSTRACT**
An apparatus configured to be removably attached to a tire/hub assembly of a vehicle via lug nuts of the tire/hub assembly is used to determine imbalance forces of the tire/hub assembly during motion of the vehicle. The apparatus includes a disk and a plurality of cup-shaped objects fixed at one end to the disk and extending perpendicularly outward from the disk. The plurality of cup-shaped objects are arranged a fixed radial distance from a radial center of the disk in a pattern that matches the lug nuts of the tire/hub assembly. The apparatus is mounted to the vehicle's tire/hub assembly by fitting the plurality of cup-shaped objects over the lug nuts of the tire/hub assembly. The apparatus further includes one or more inertial measurement units (IMU's) mounted to the disk to measure parameters that are used for calculating the imbalance forces during motion of the vehicle.

14 Claims, 31 Drawing Sheets

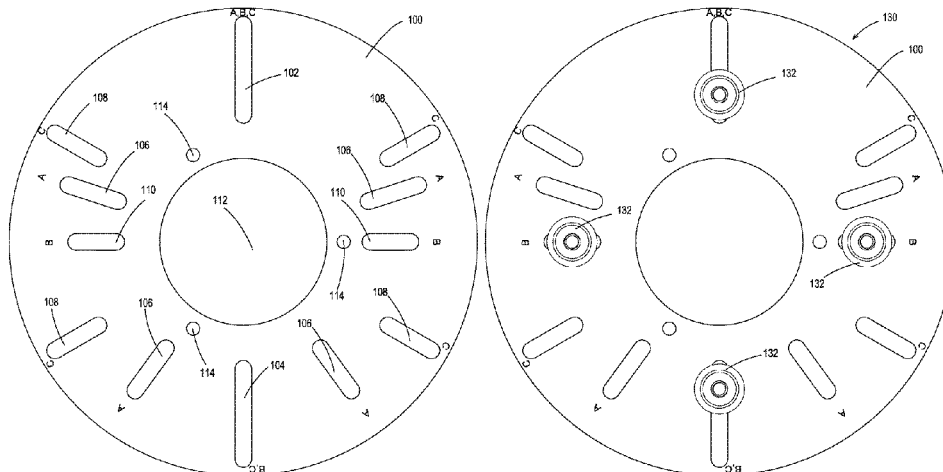

(56)

References Cited

U.S. PATENT DOCUMENTS

6,595,053	B2	7/2003	Parker	
7,926,189	B1*	4/2011	Pellegrino	G01B 5/255 33/203.18
10,284,752	B1	5/2019	Canfield et al.	
2005/0247130	A1	11/2005	Takada et al.	
2006/0010992	A1*	1/2006	Shima	B60C 23/066 73/862.69
2008/0185106	A1	8/2008	Farley et al.	
2017/0350684	A1*	12/2017	Maliszewski	G01B 21/26

OTHER PUBLICATIONS

International Search Report and Written Opinion dated Oct. 27, 2020 in International Application No. PCT/US2020/044692.
Product brochure for Road Force Elite® wheel balancer, Hunter Engineering Company, Copyright © 2018, 16 pages.
Ford F150 2004-2014 Center Cap, Copyright © 2019 centercaps.net, 2 pages.

* cited by examiner

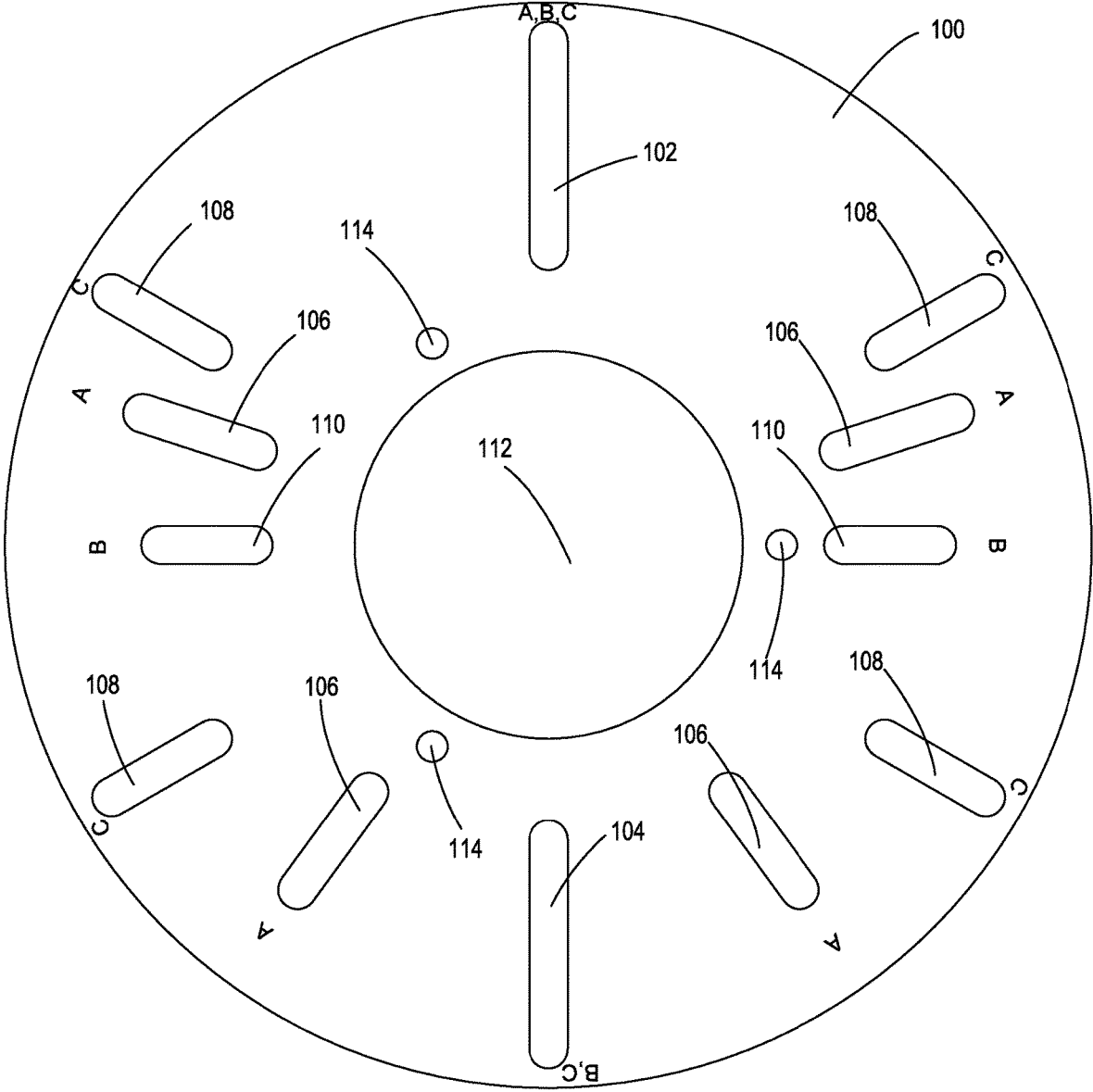

Fig. 1A

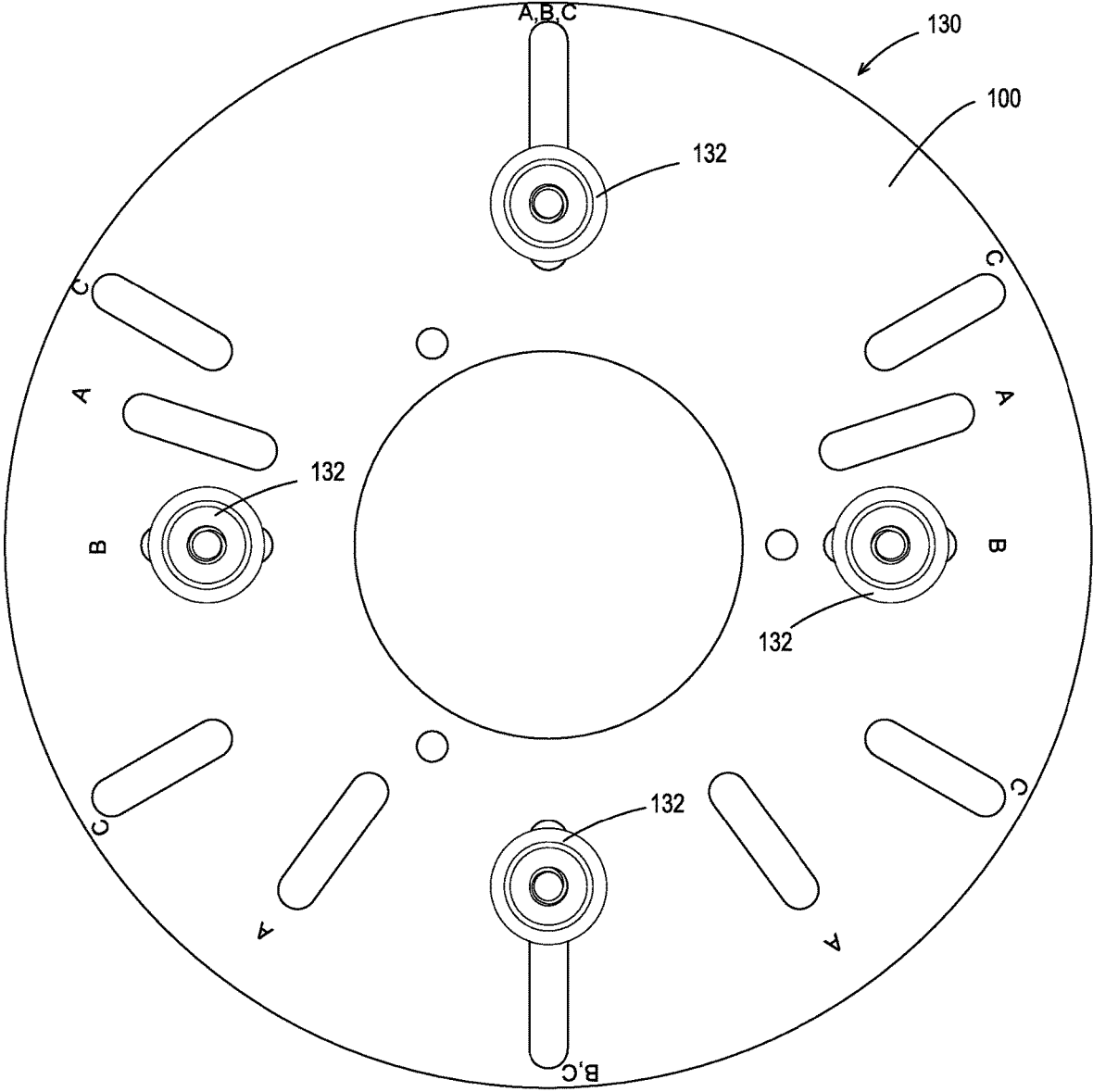

Fig. 1B

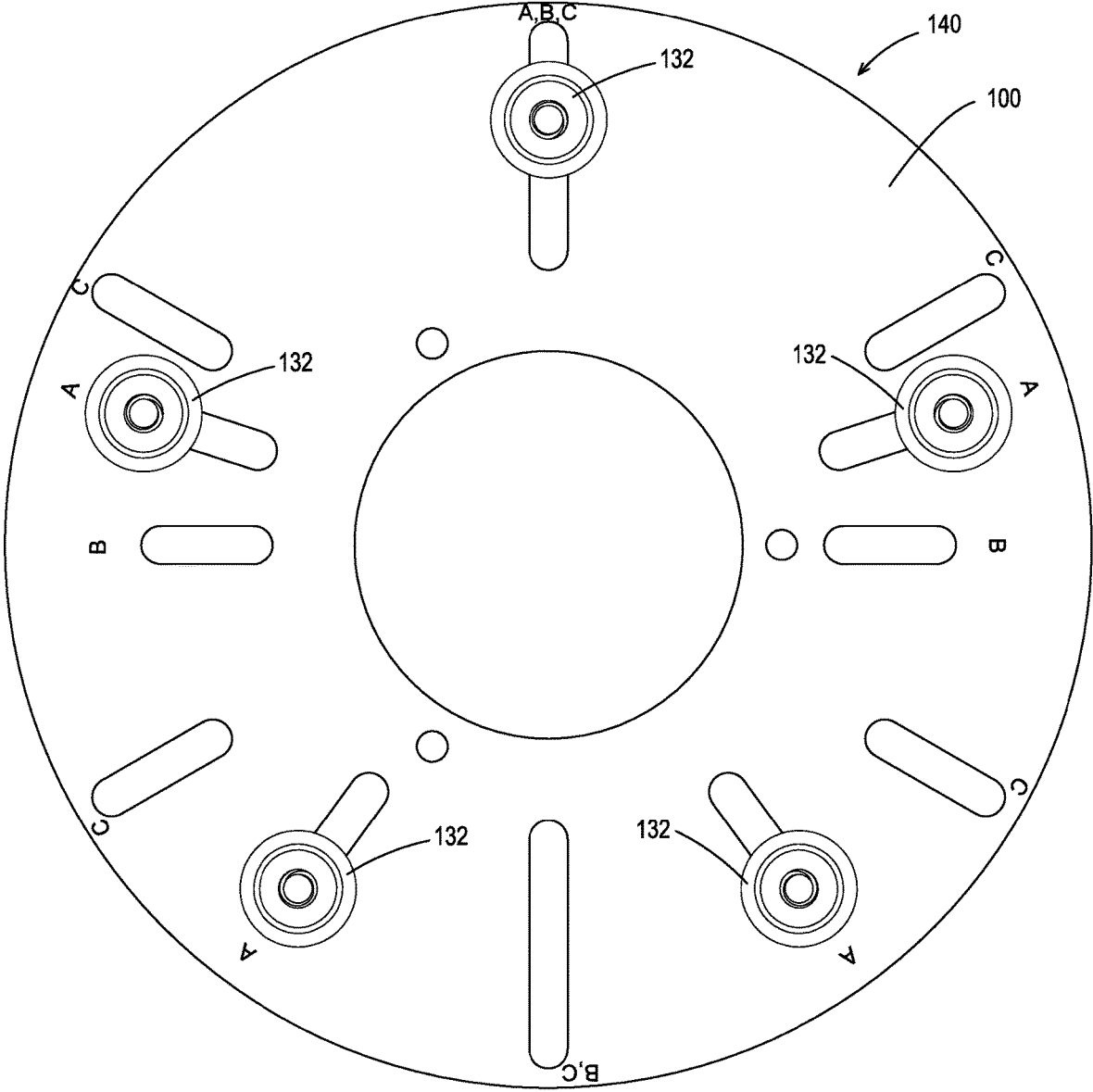

Fig. 1C

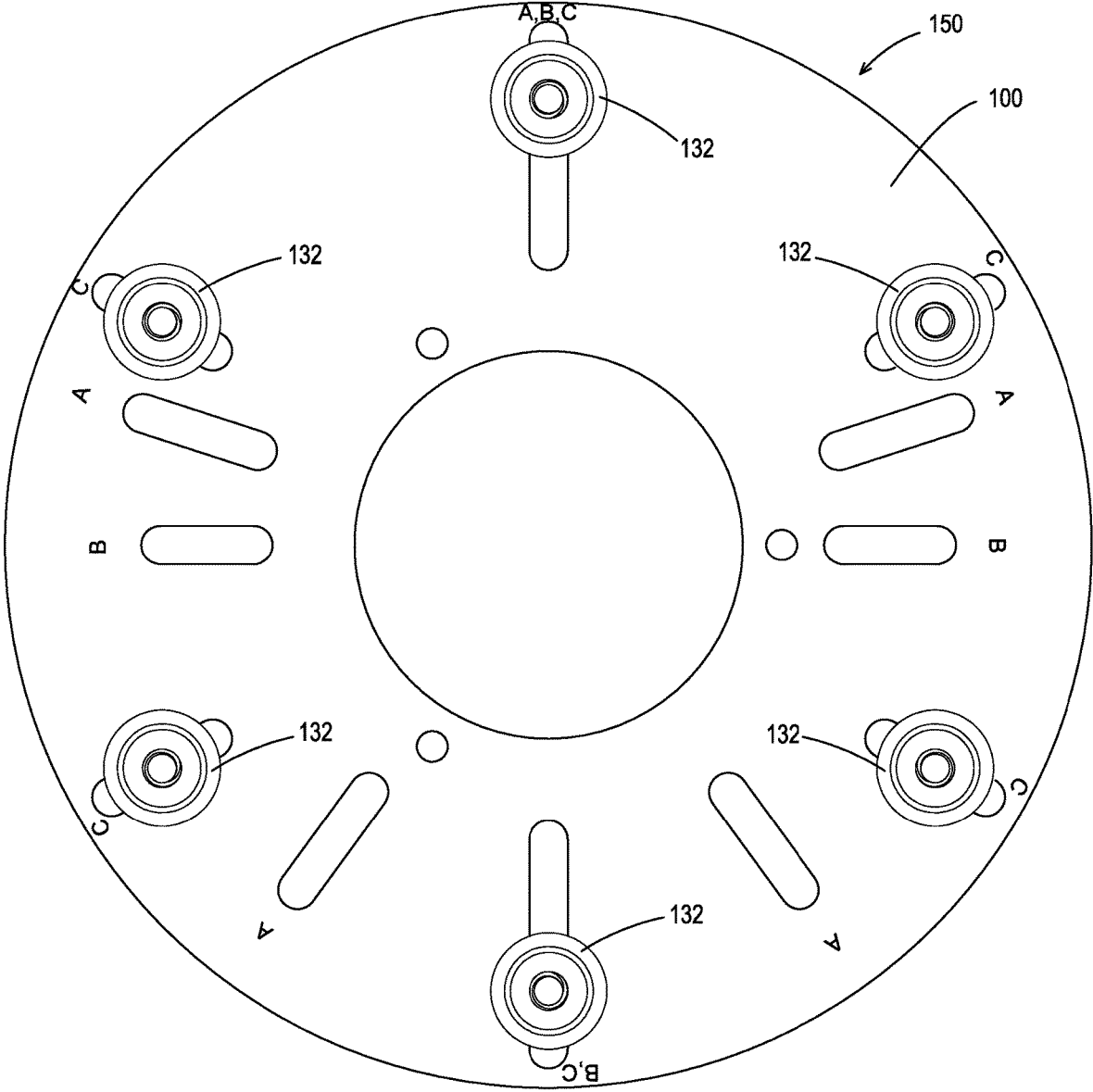

Fig. 1D

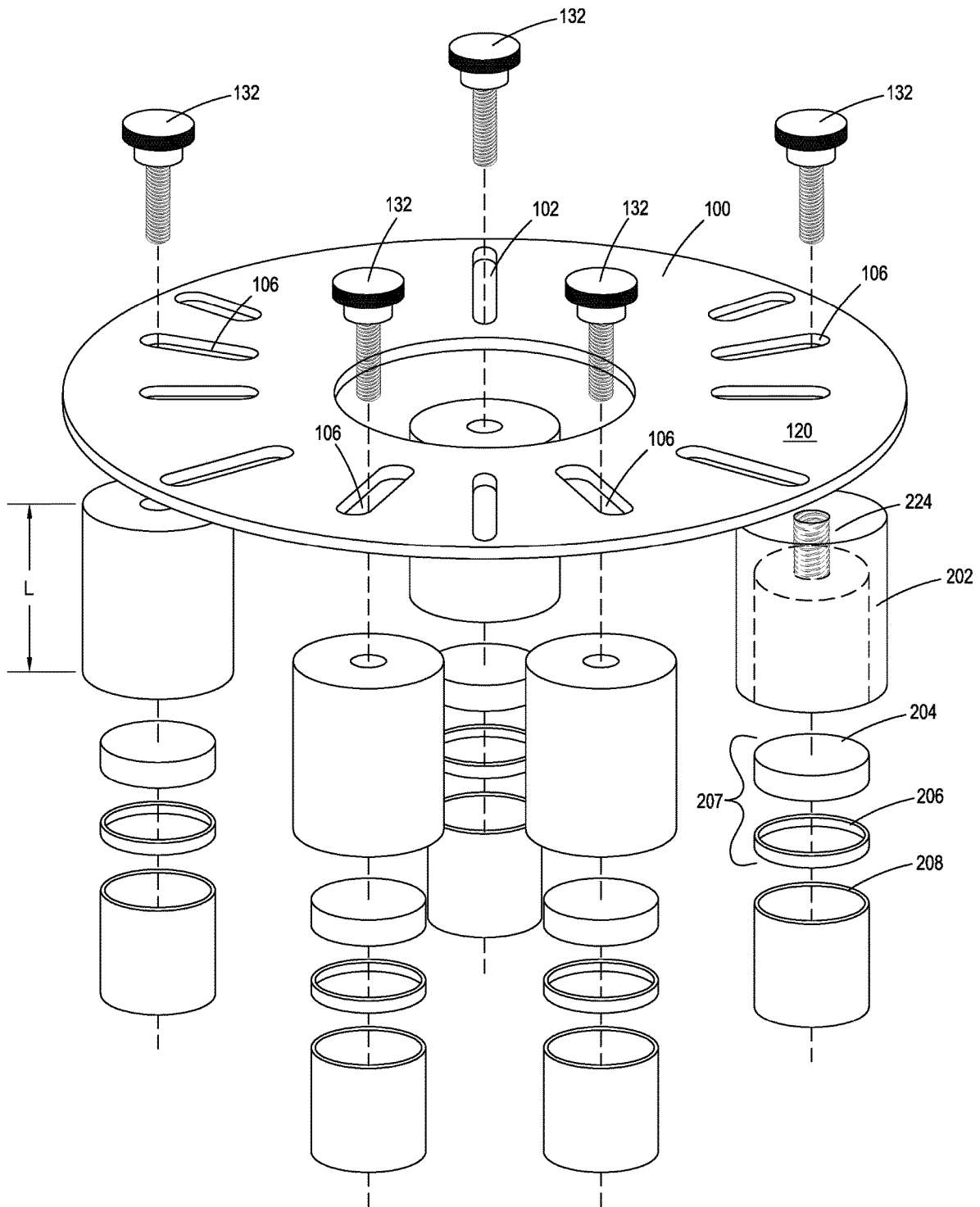

Fig. 2A

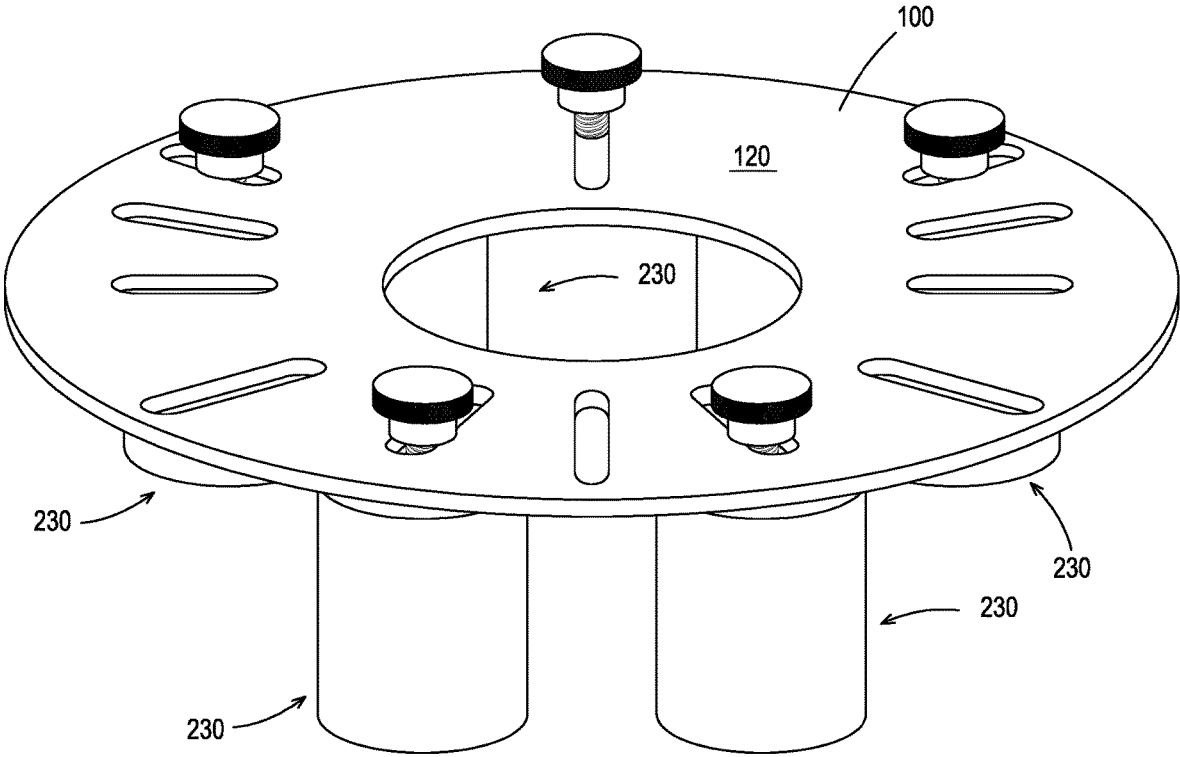

Fig. 2B

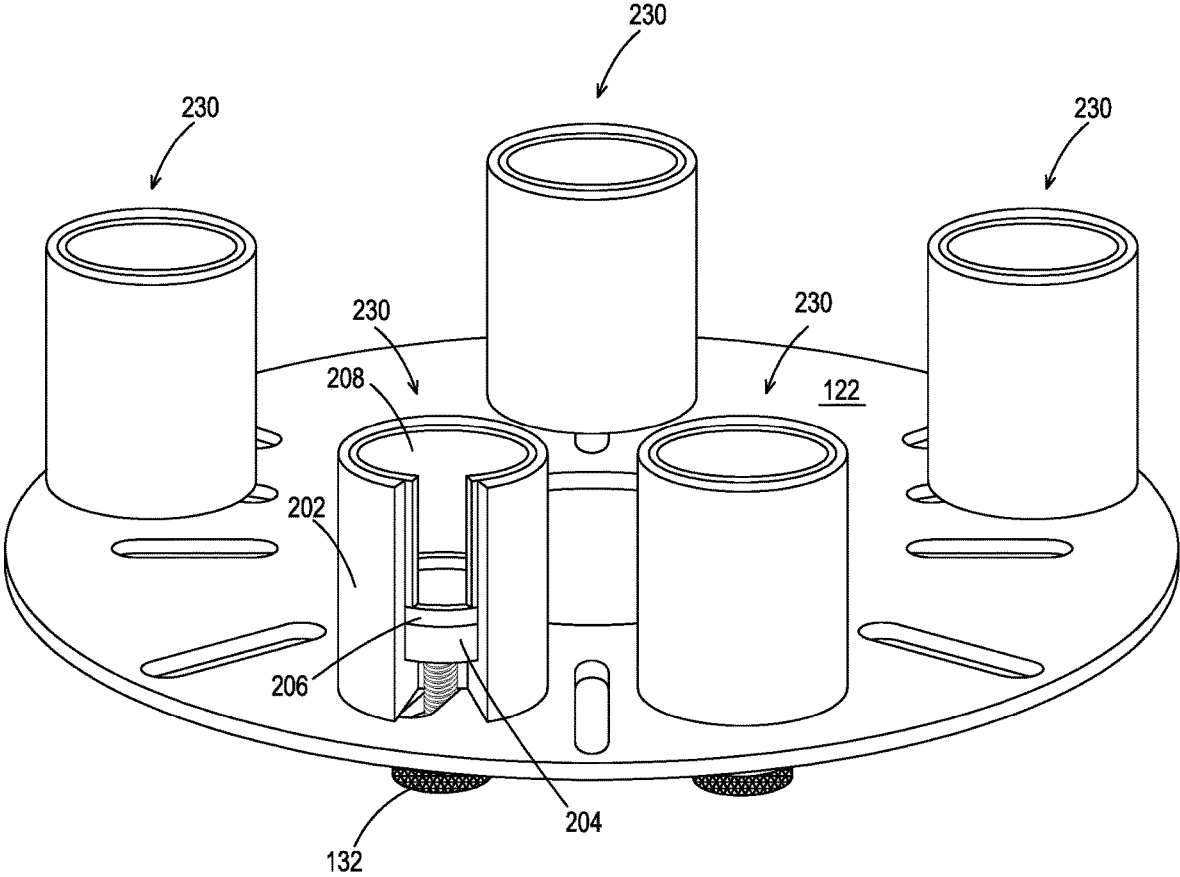

Fig. 2C

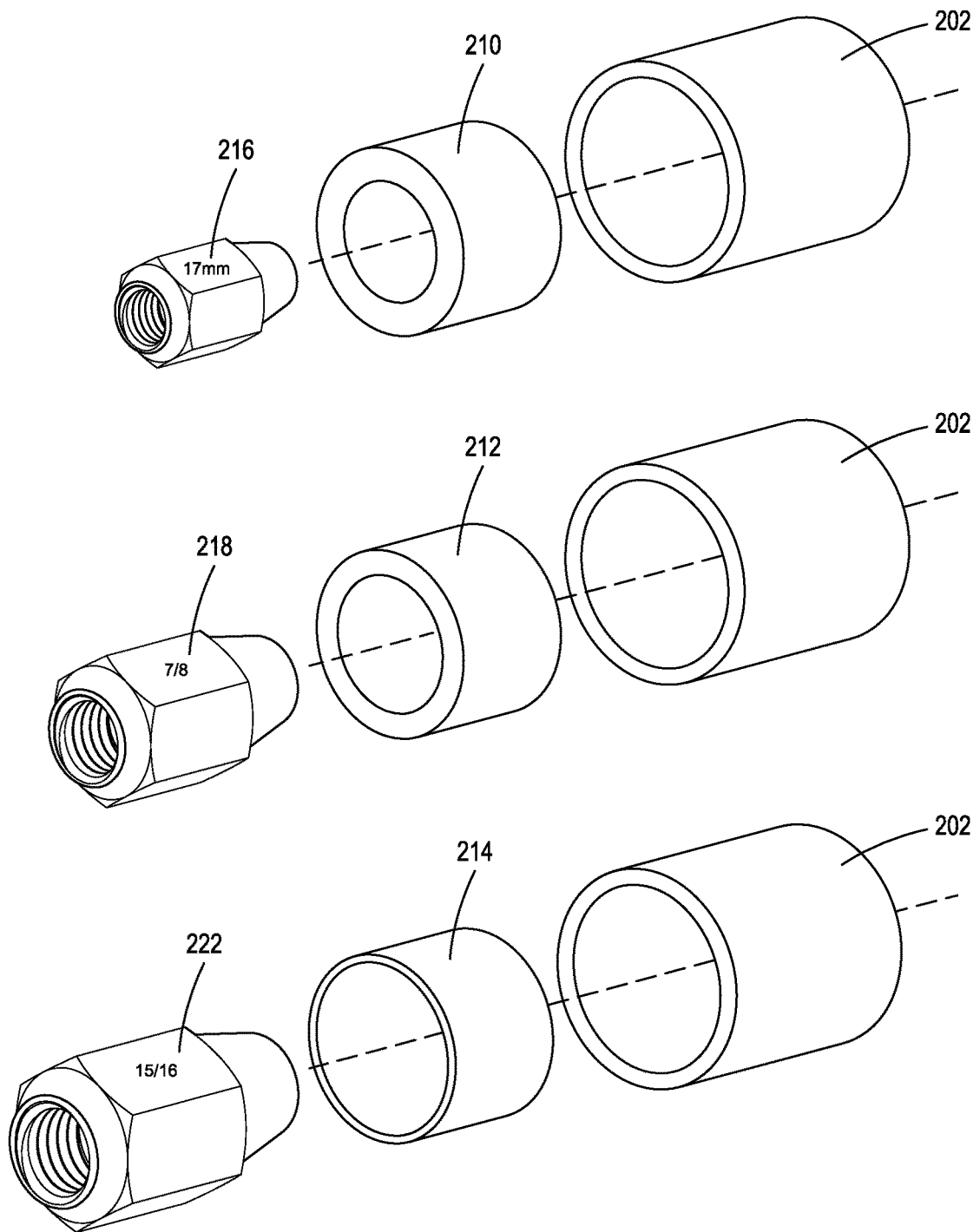

Fig. 2D

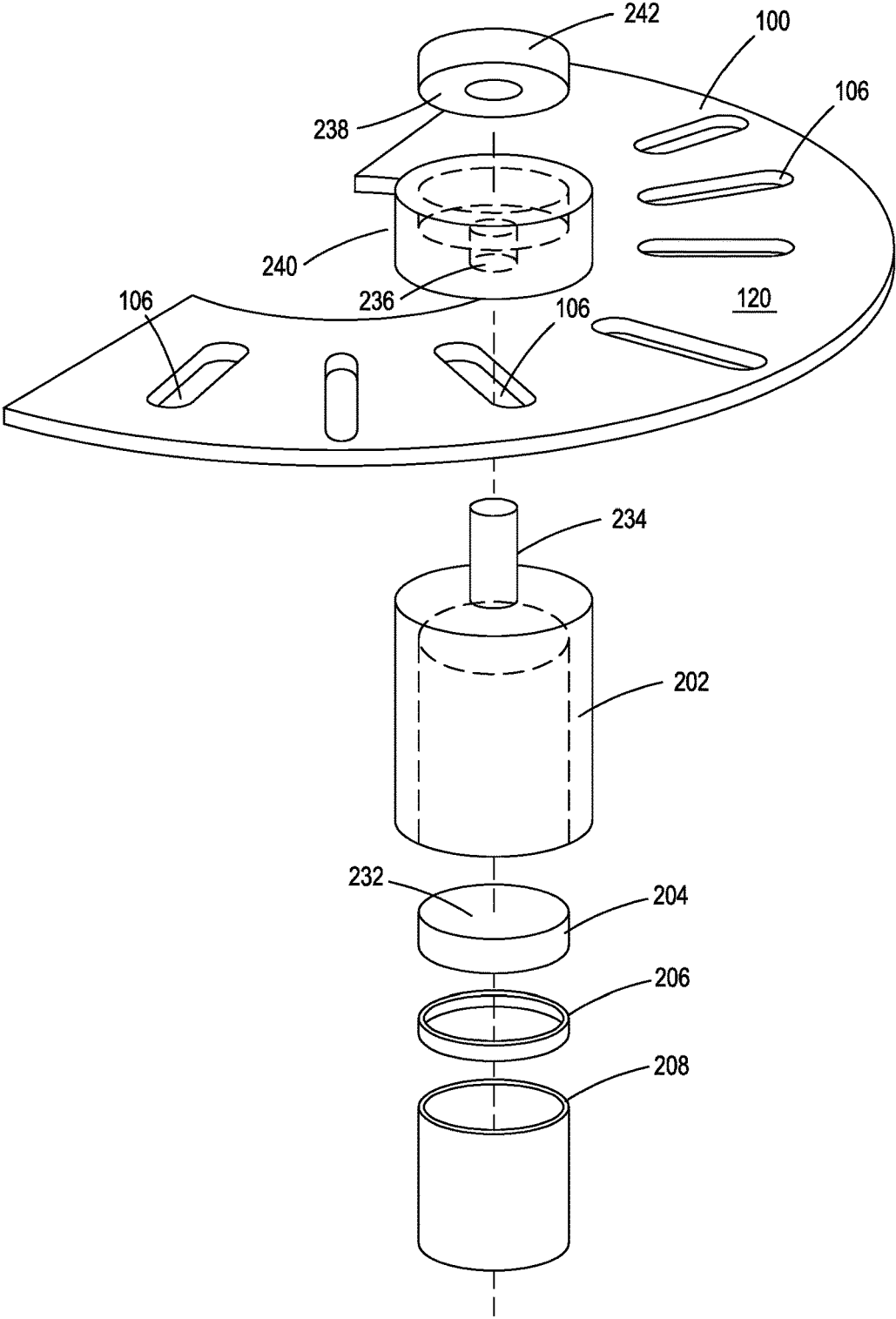

Fig. 2E

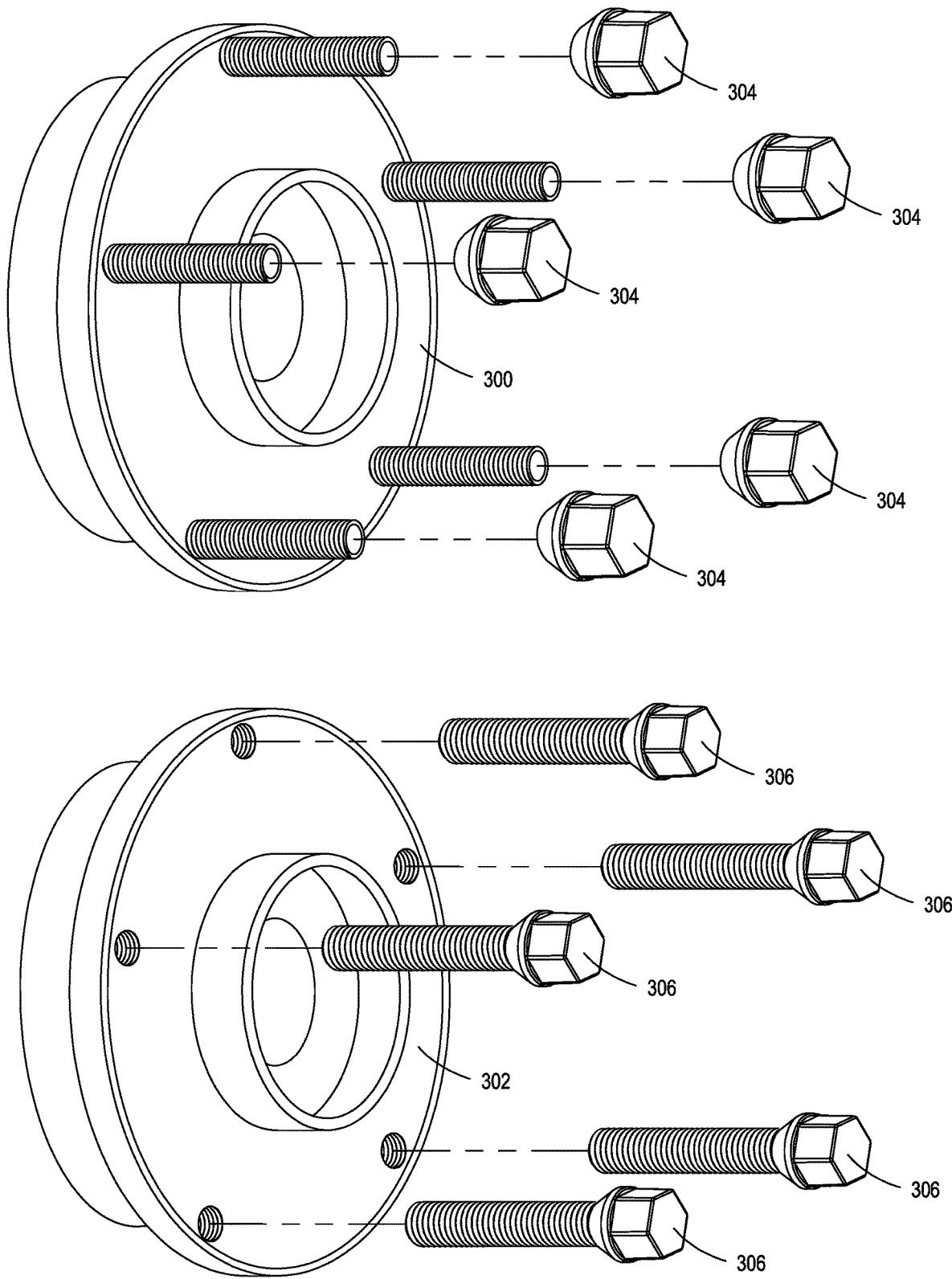

Fig. 3A (PRIOR ART)

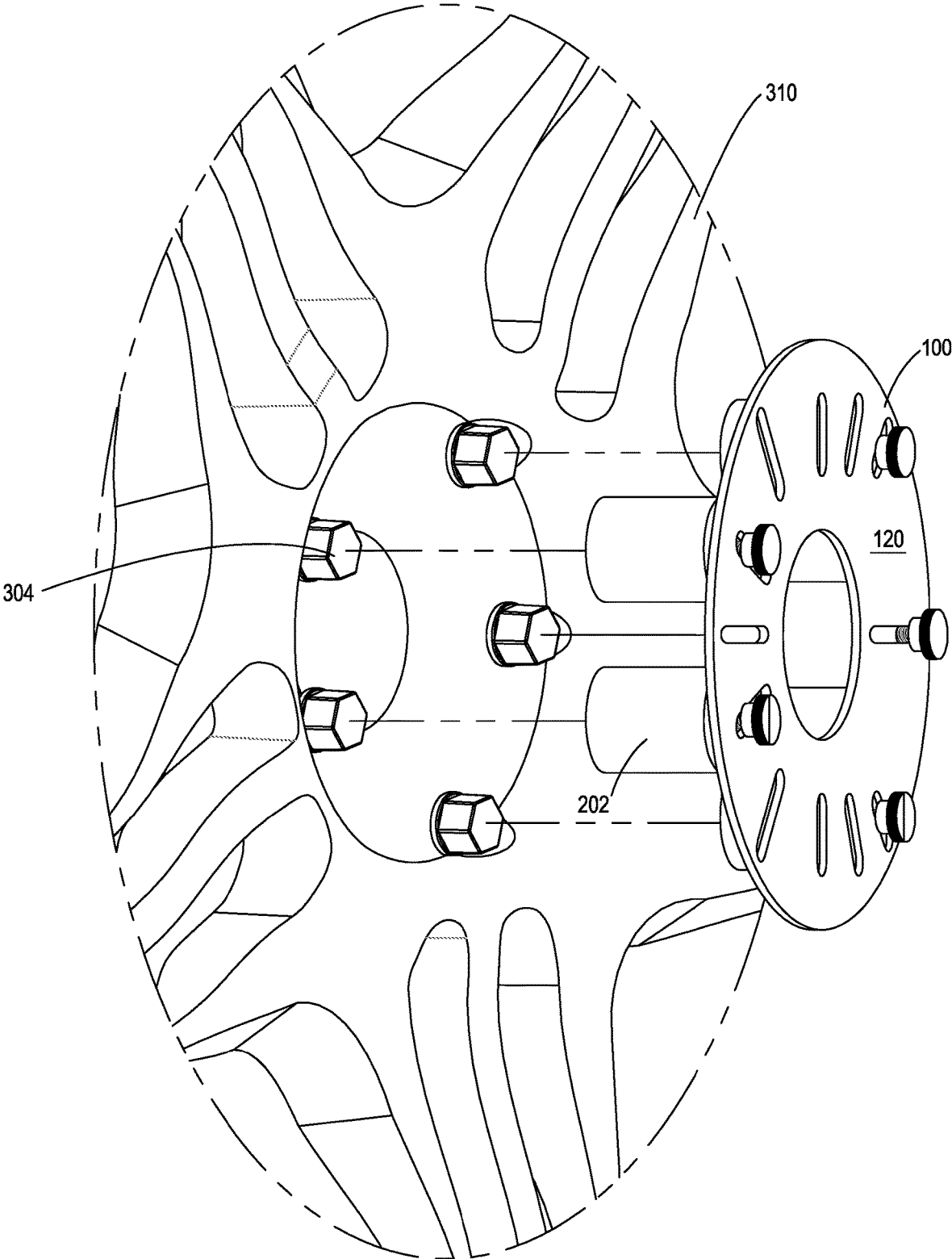

Fig. 3B

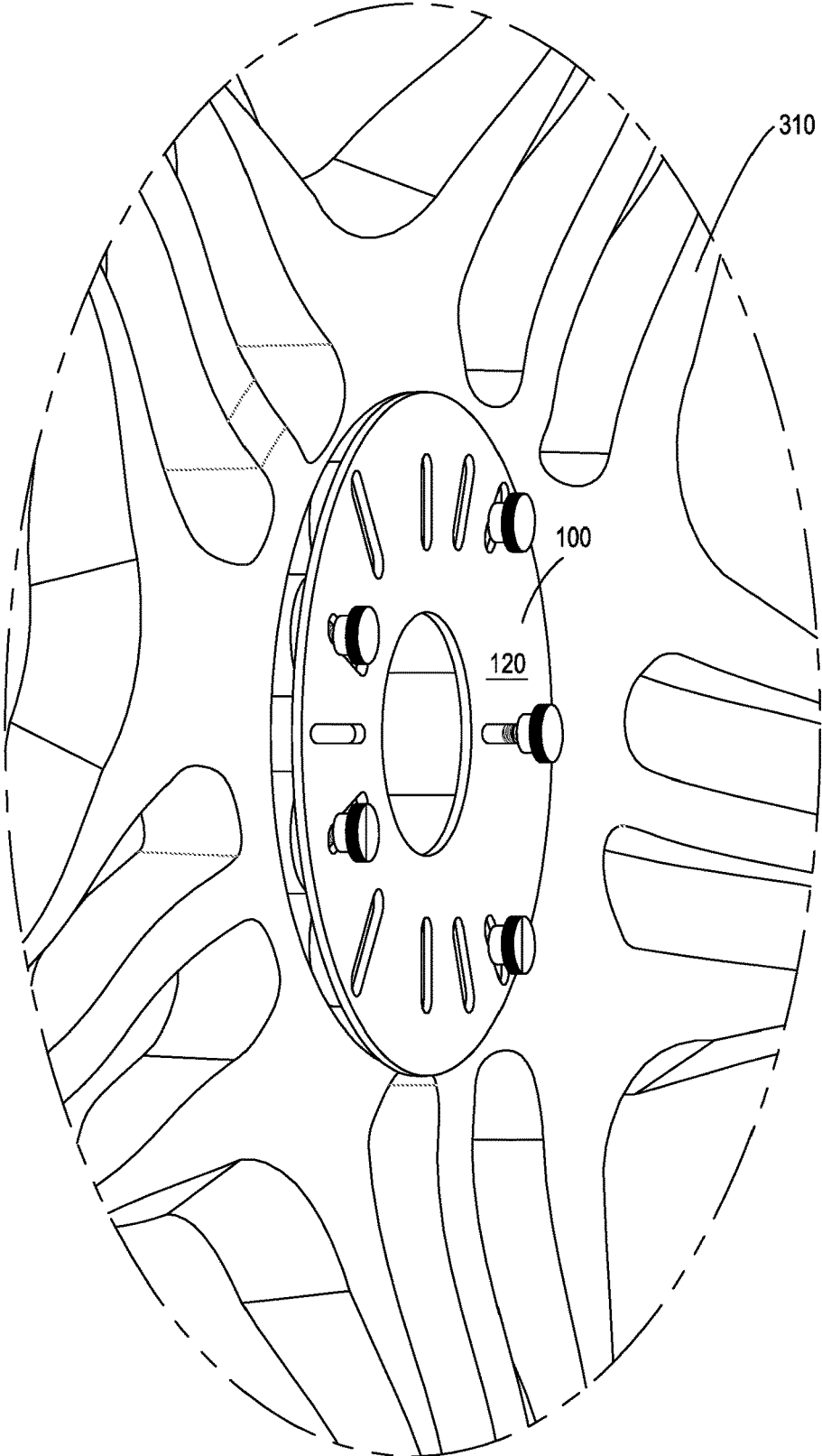

Fig. 3C

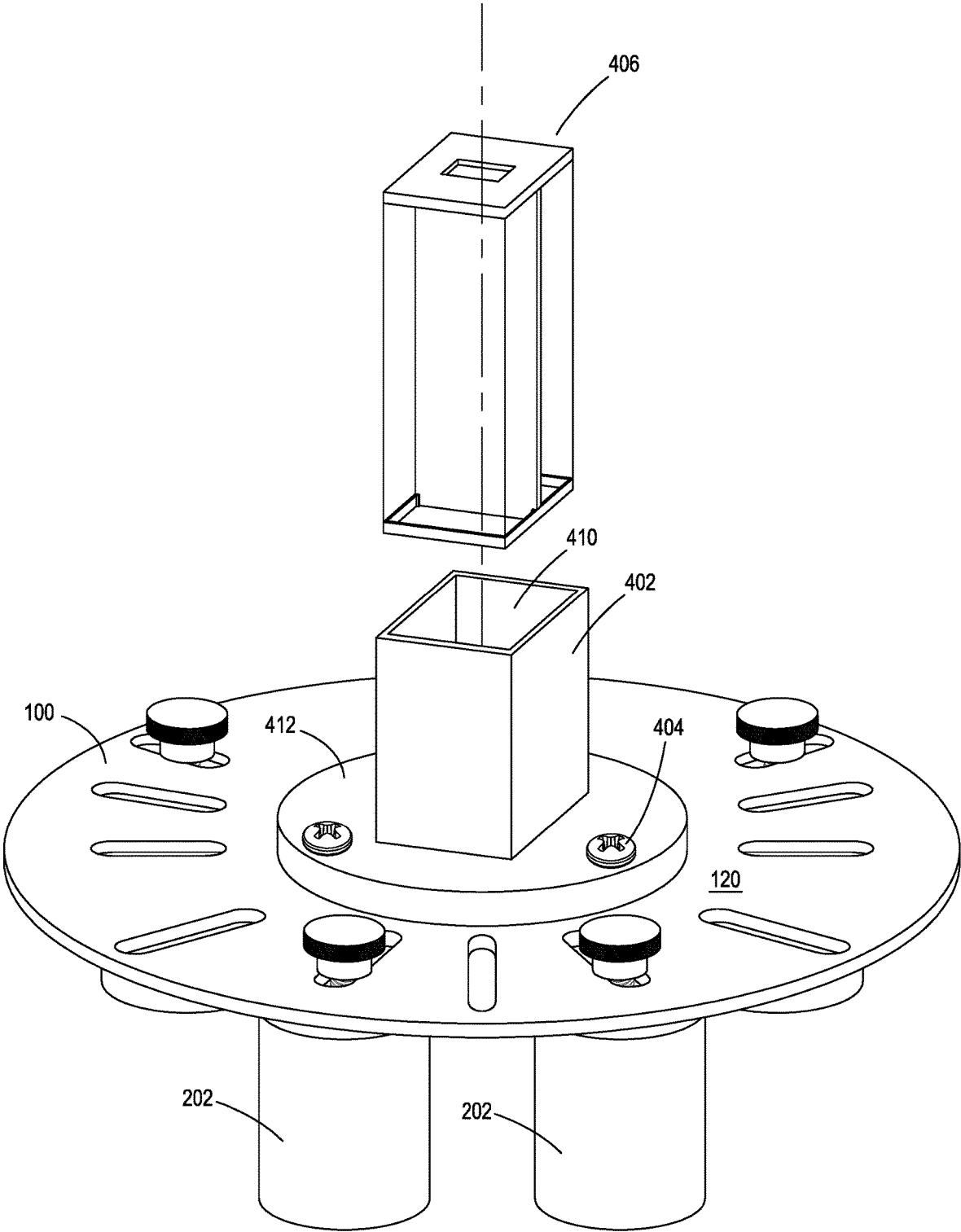

Fig. 4A

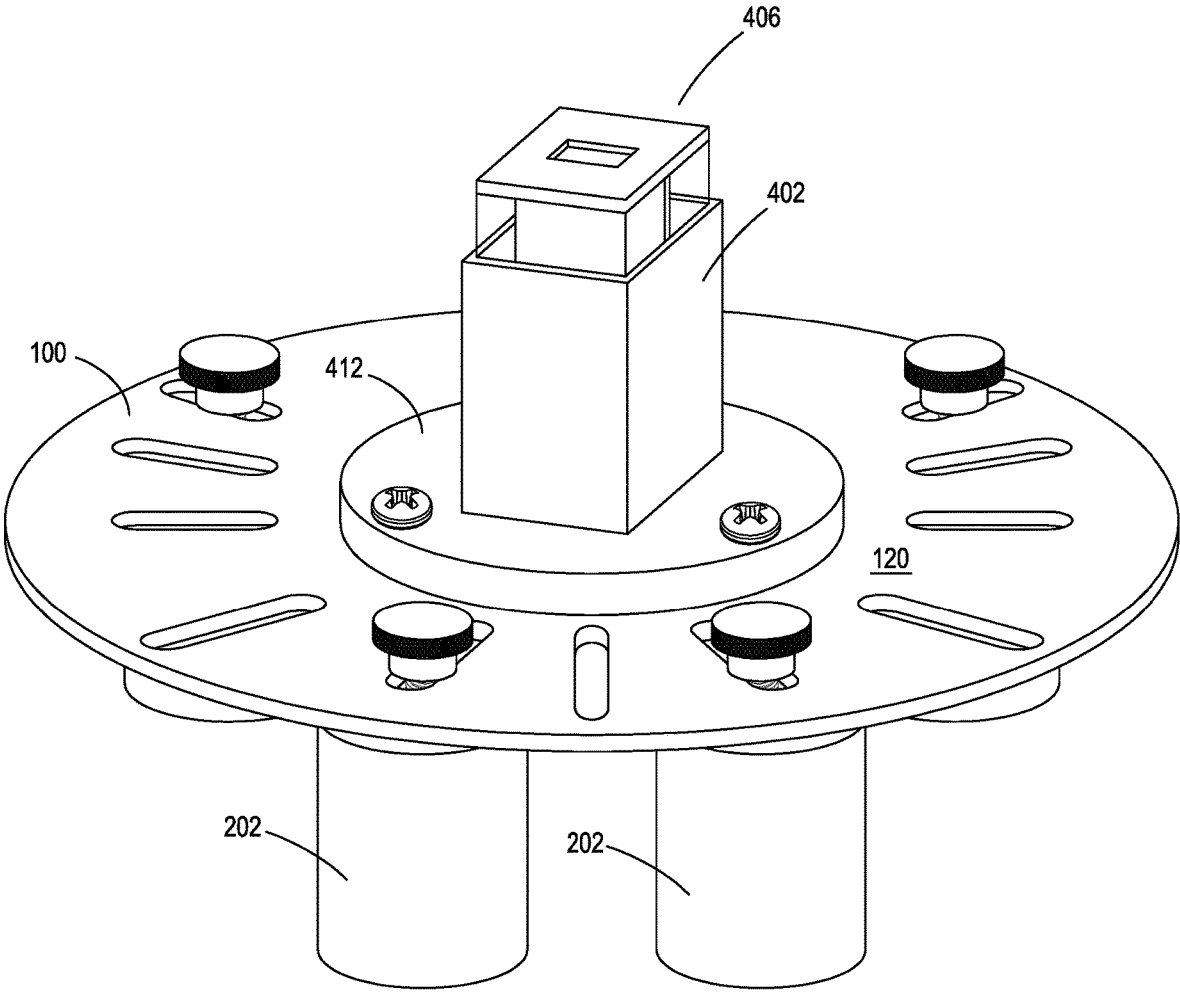

Fig. 4B

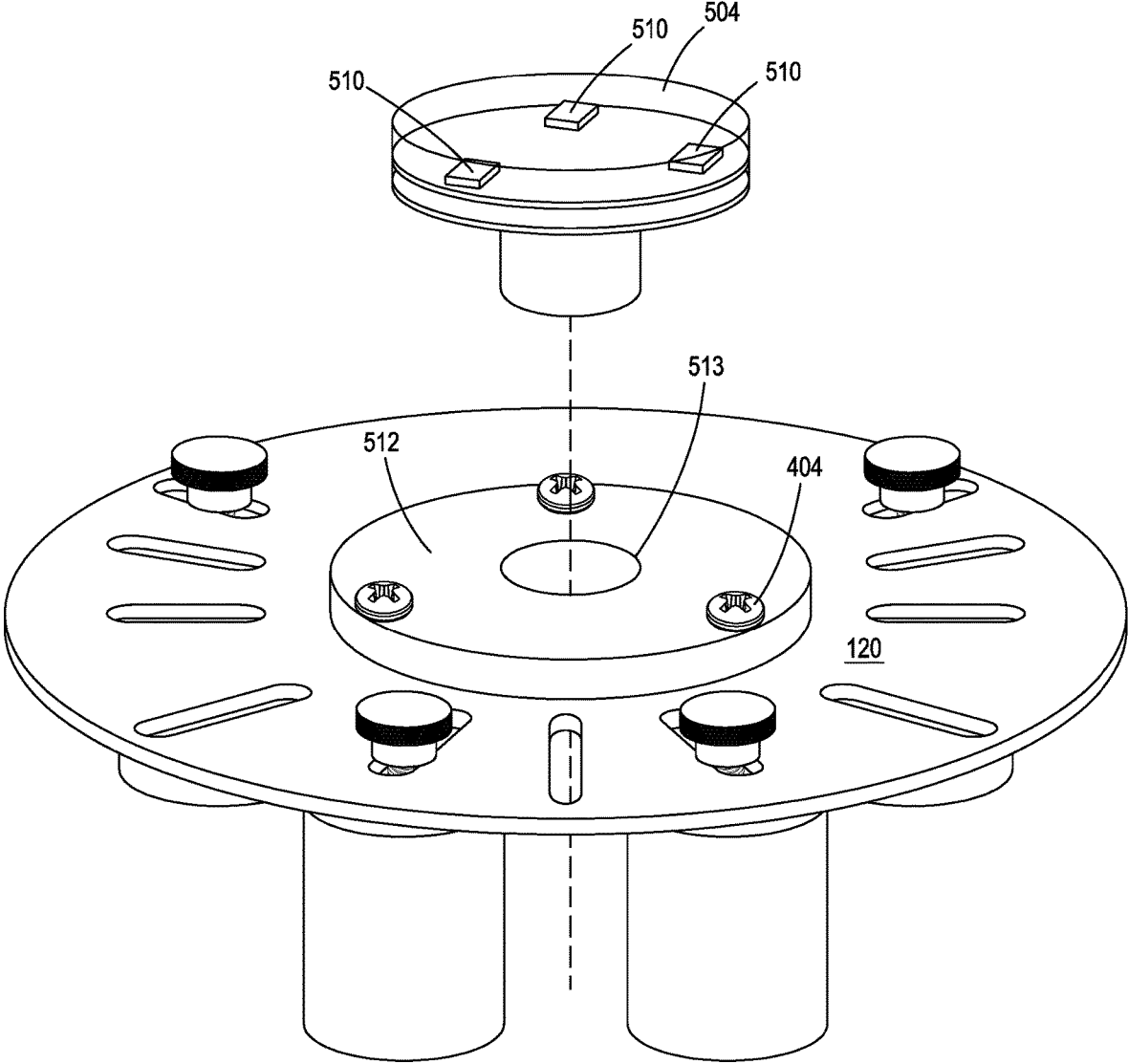

Fig. 5A

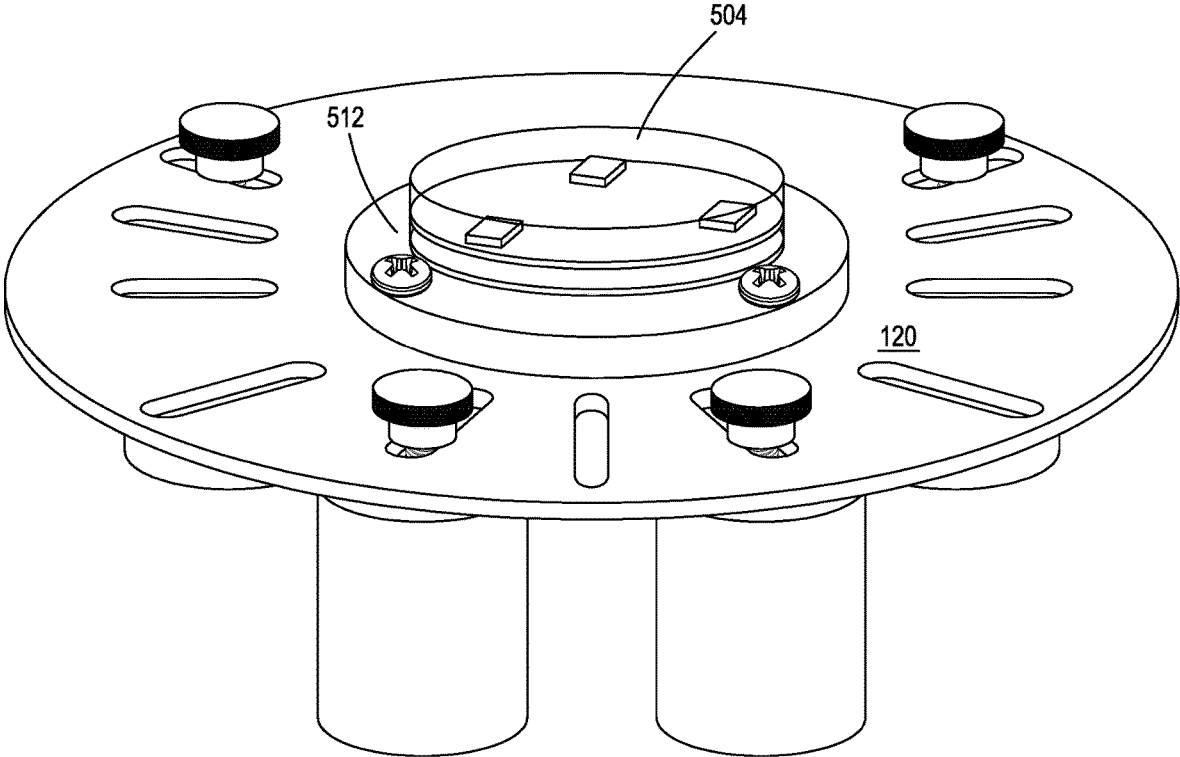

Fig. 5B

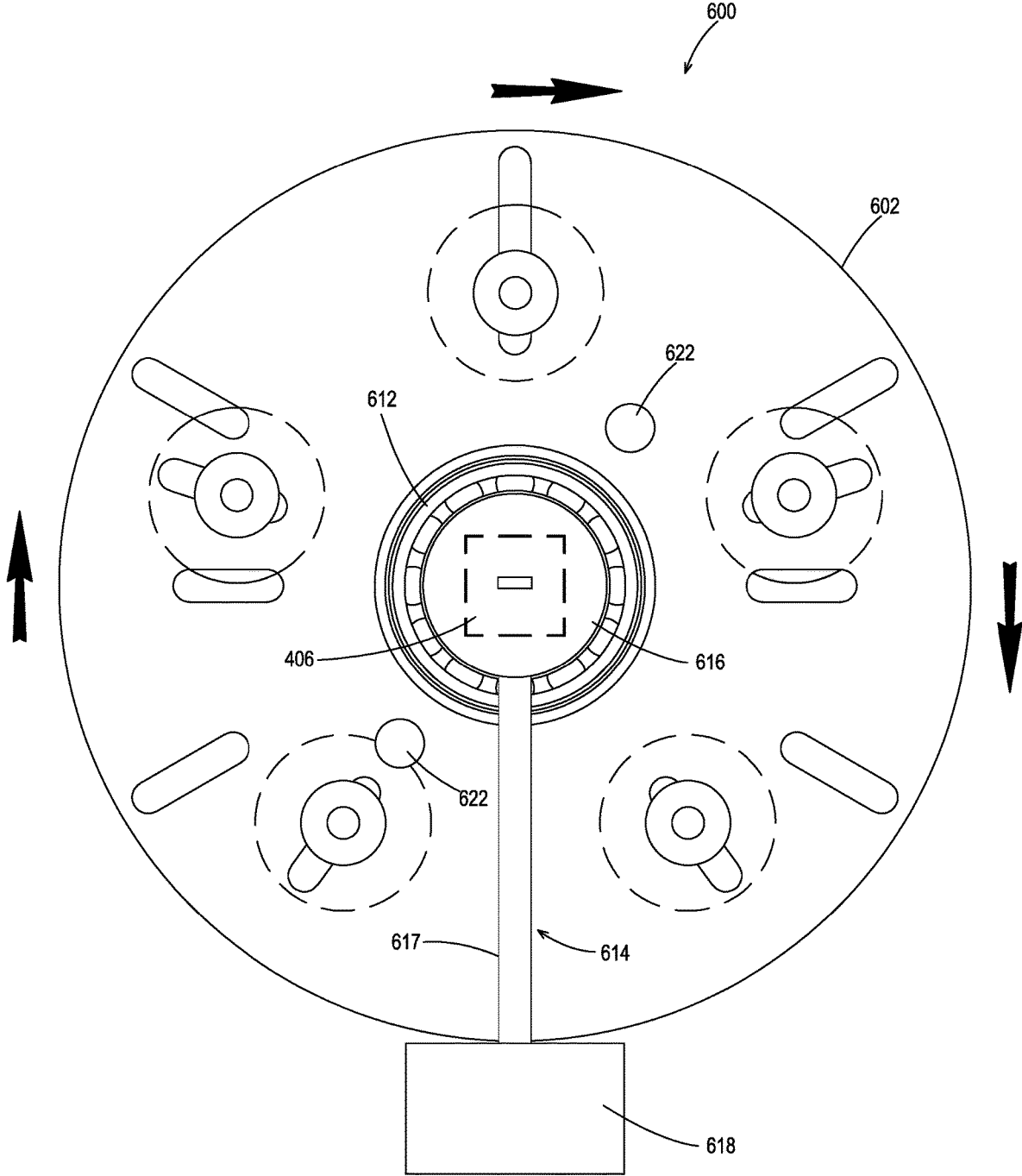

Fig. 6A

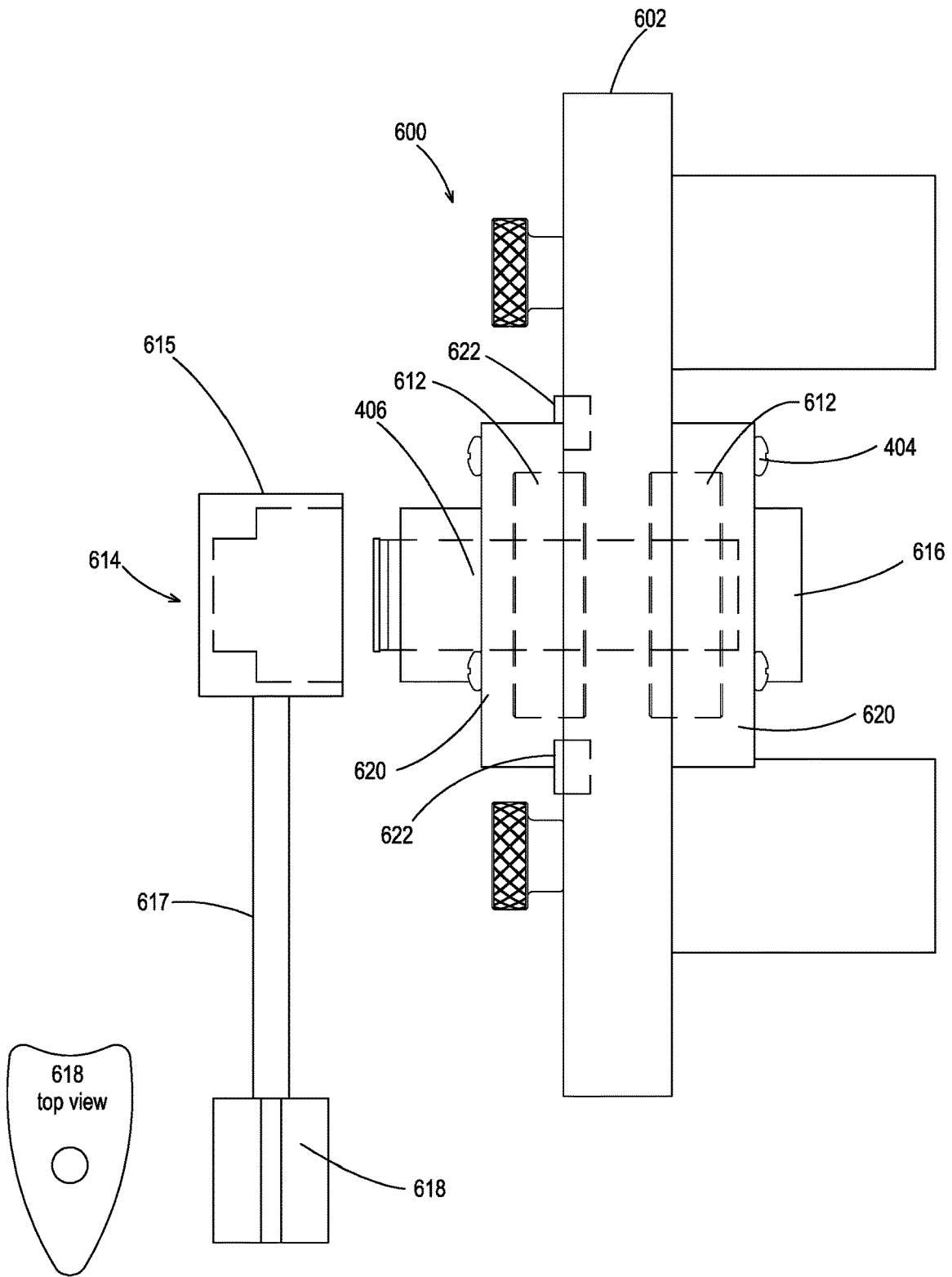

Fig. 6B

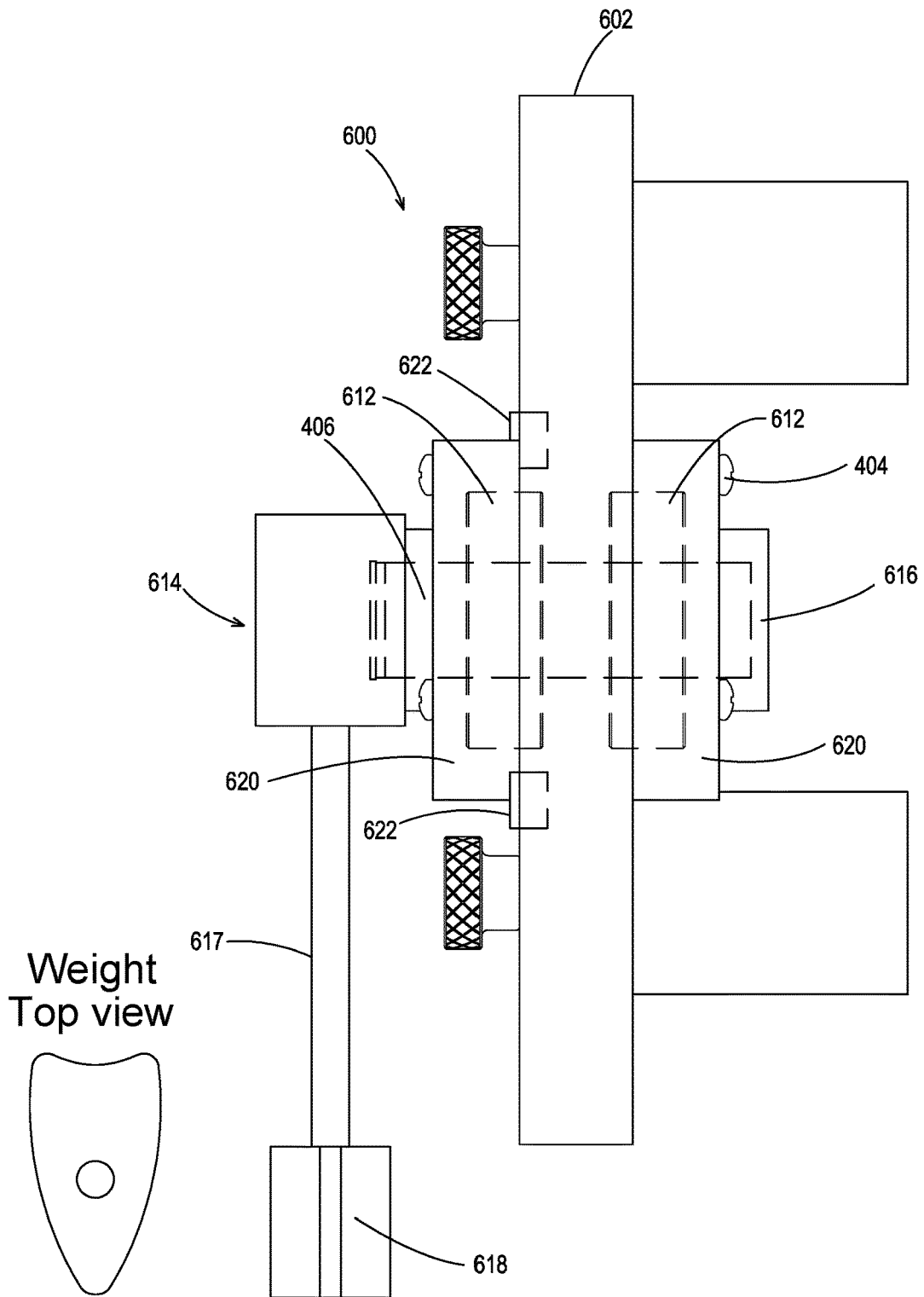

Fig. 6C

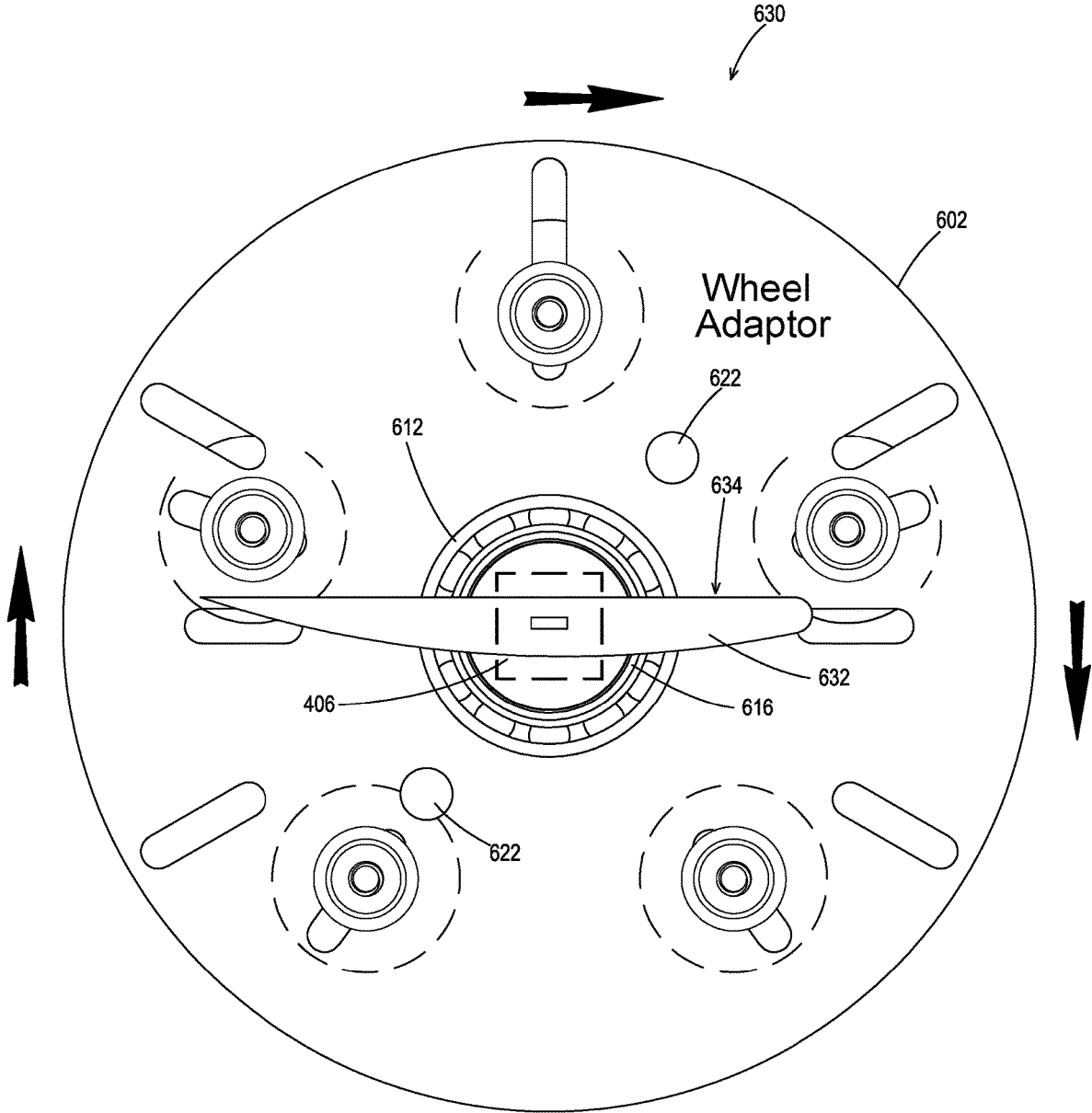

Fig. 6D

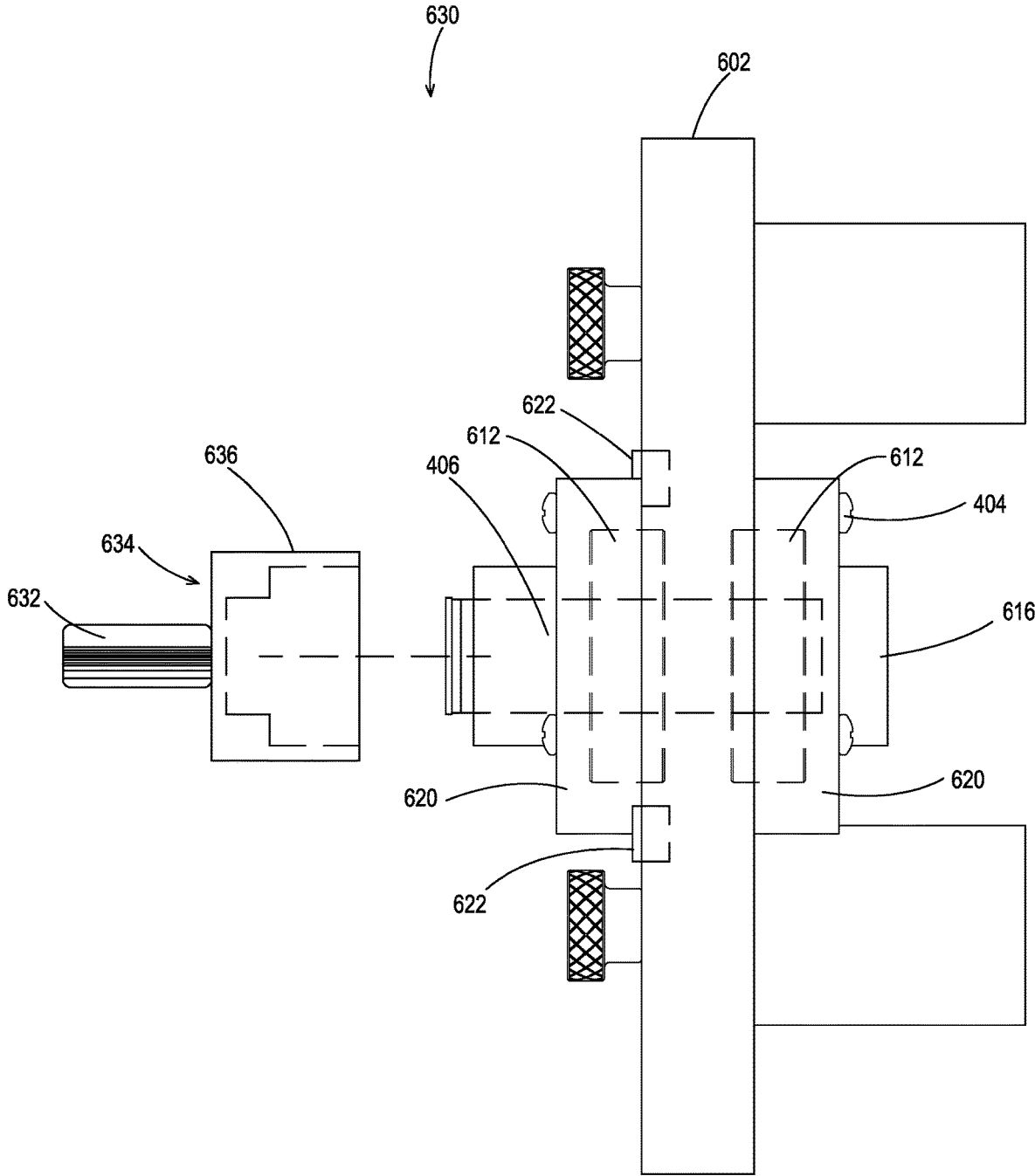

Fig. 6E

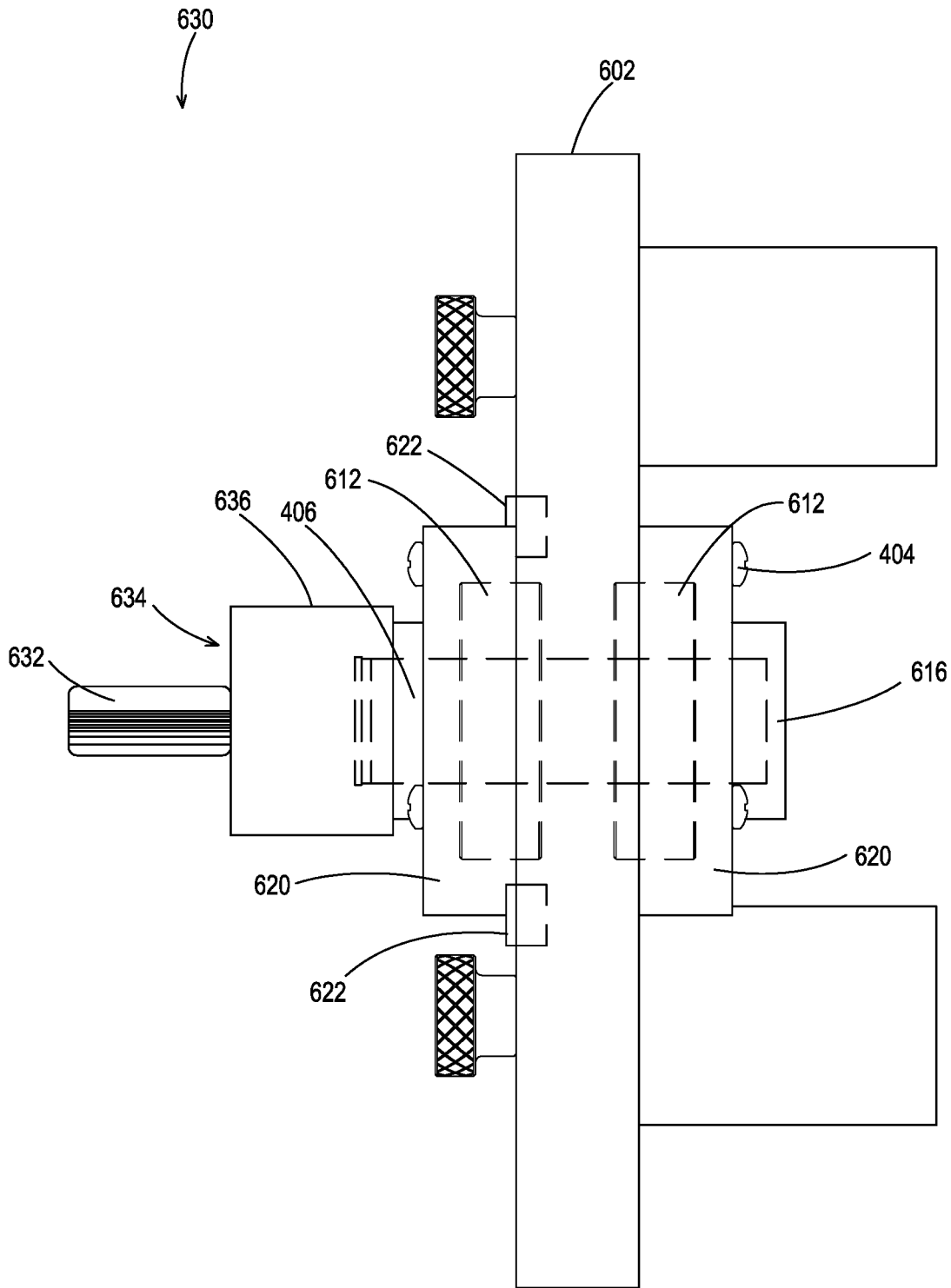

Fig. 6F

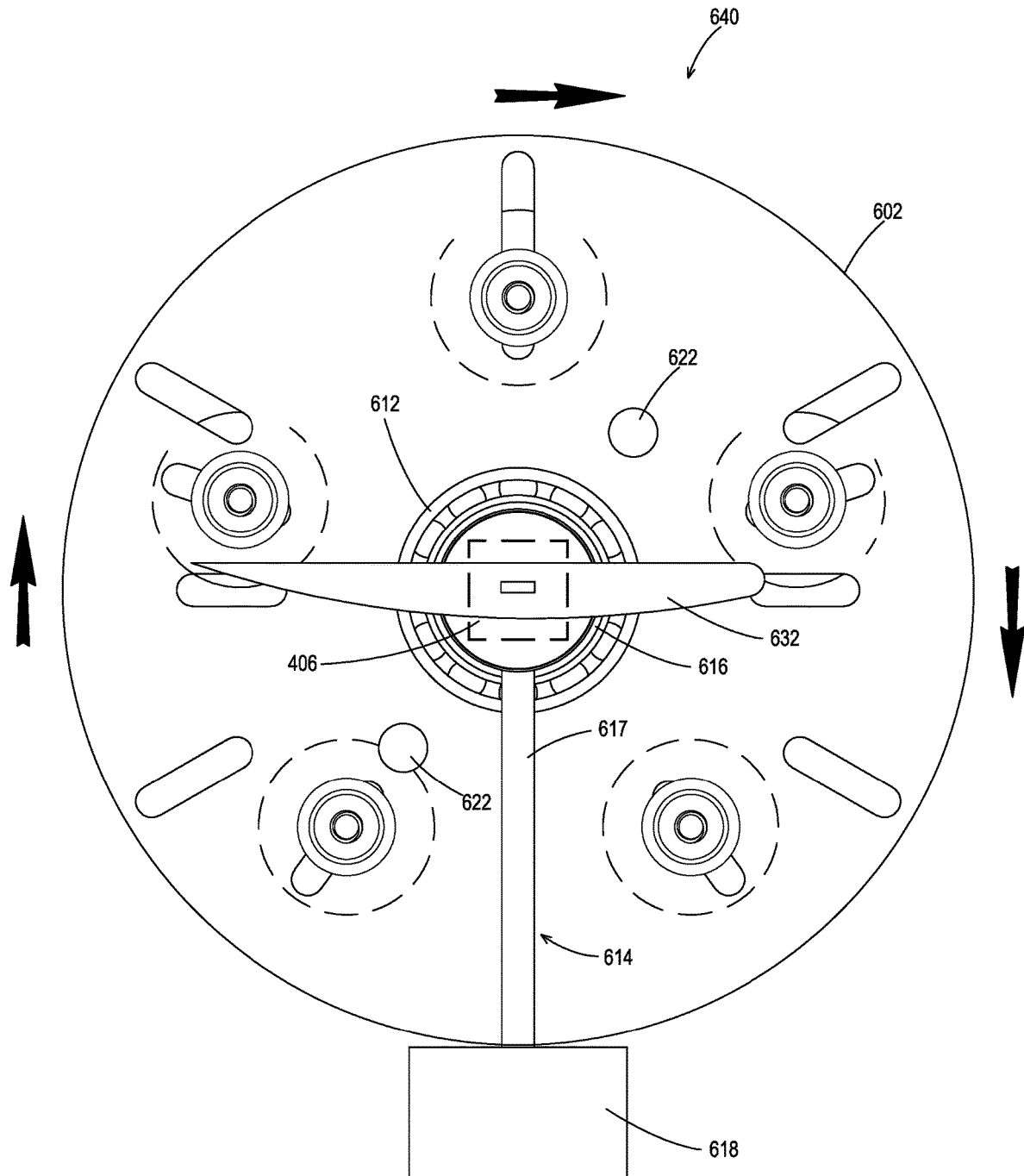

Fig. 6G

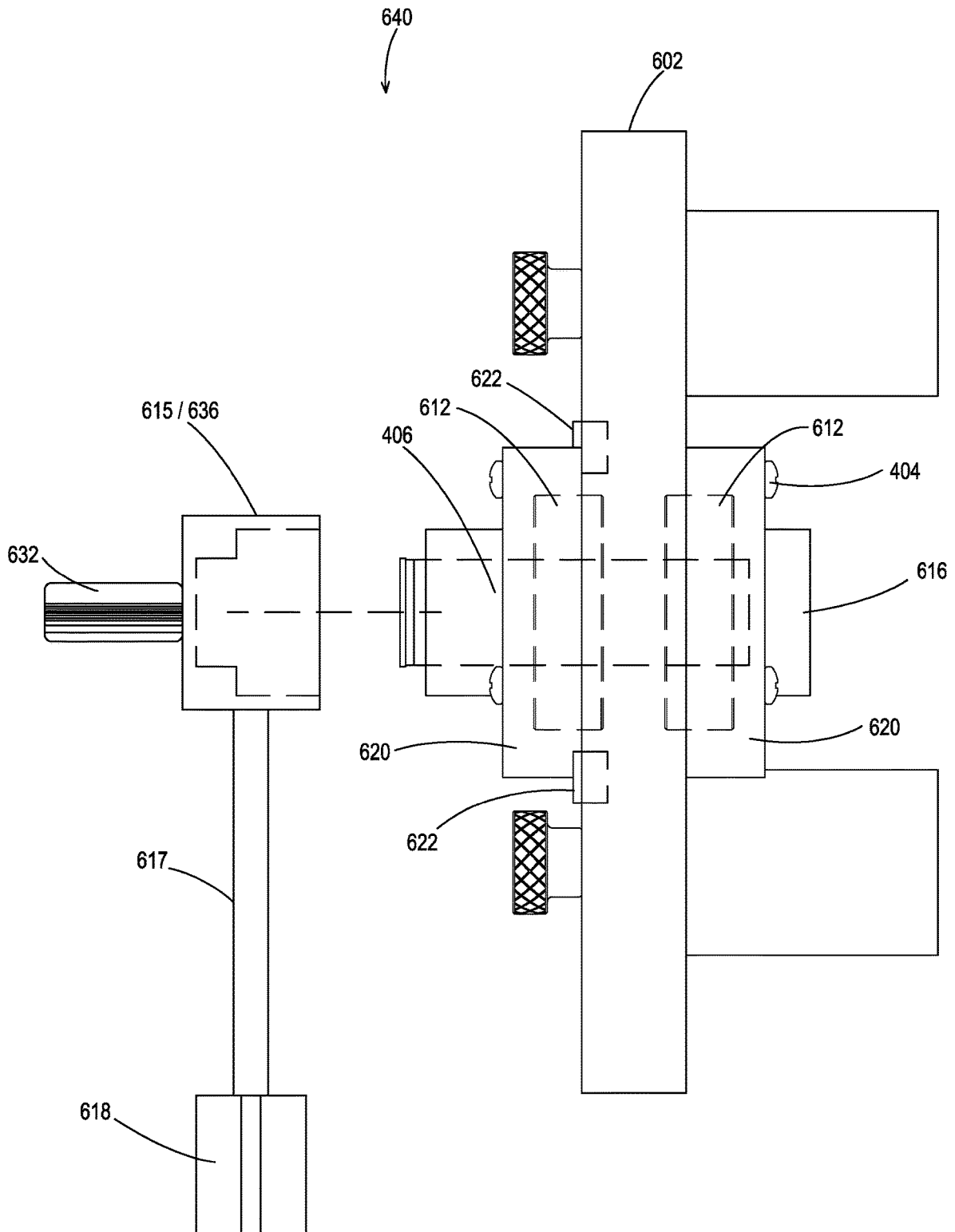

Fig. 6H

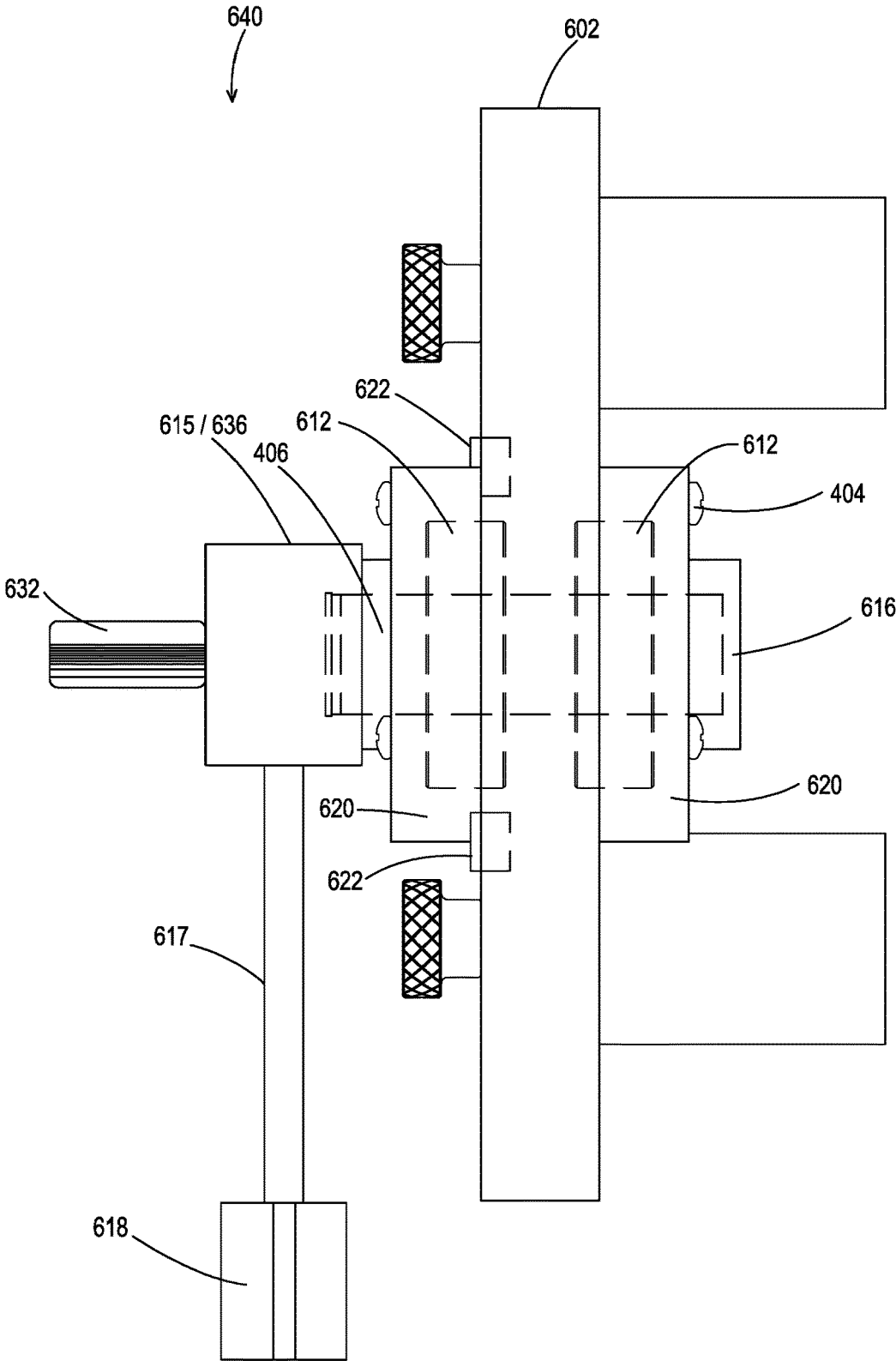

Fig. 6I

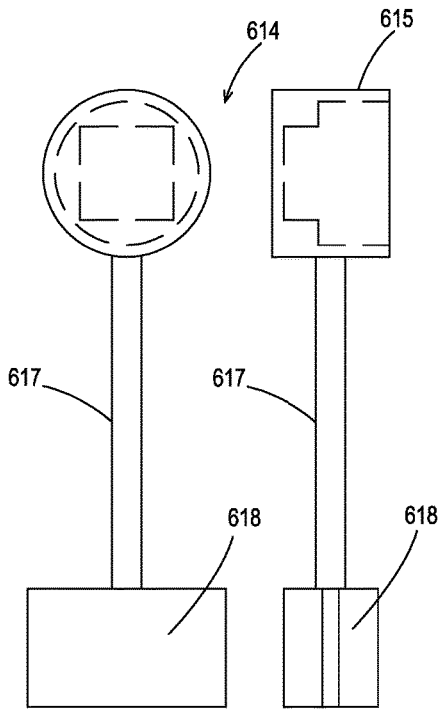

Fig. 6J

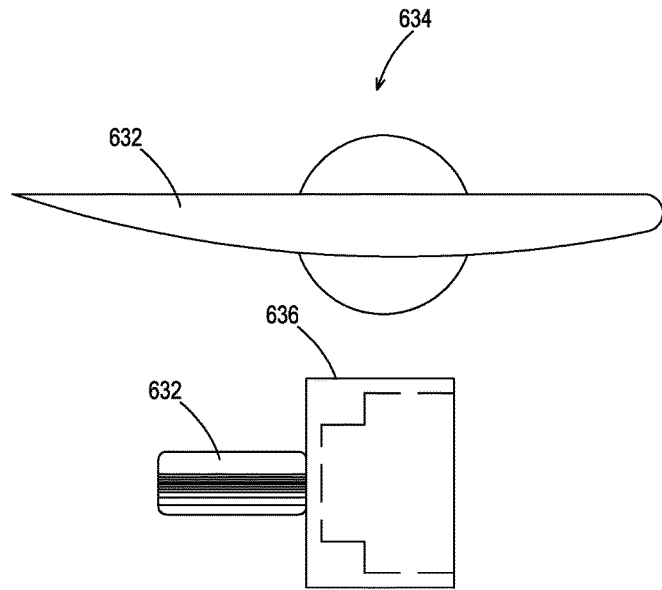

Fig. 6K

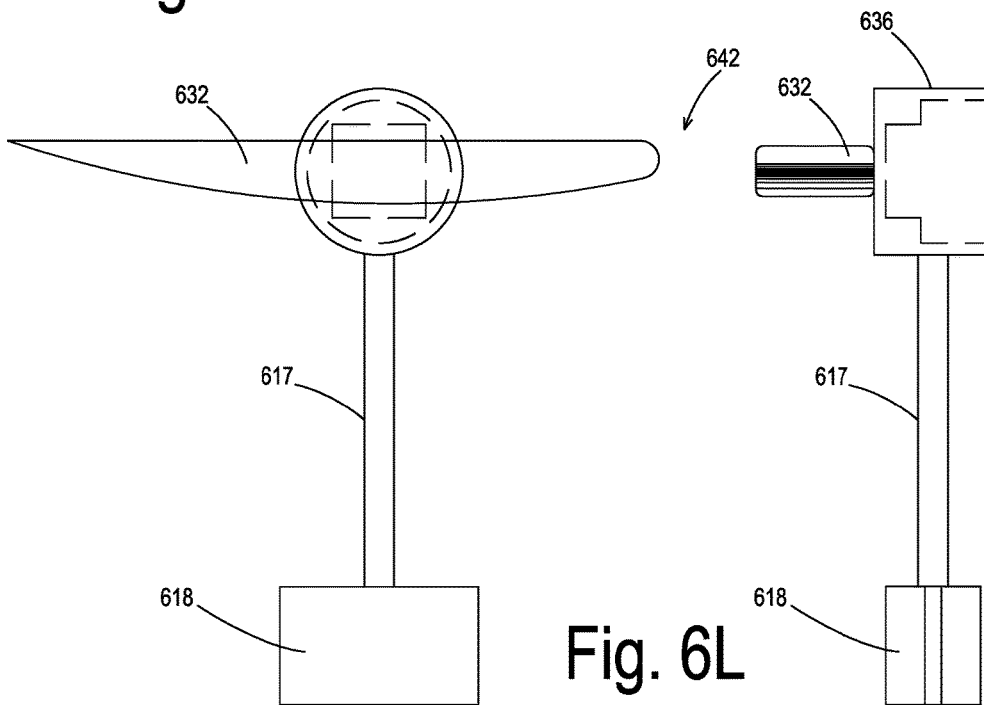

Fig. 6L

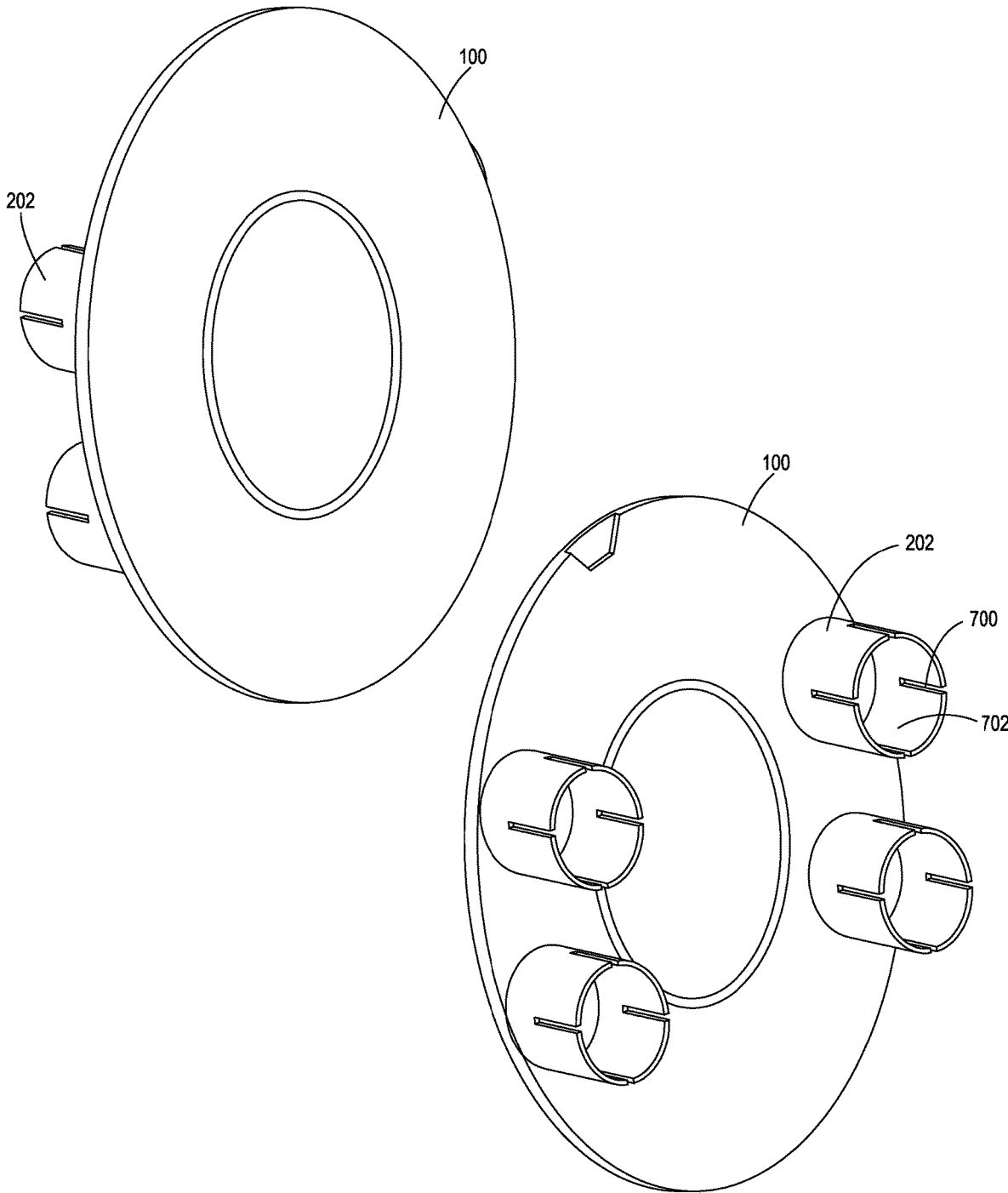

Fig. 7A

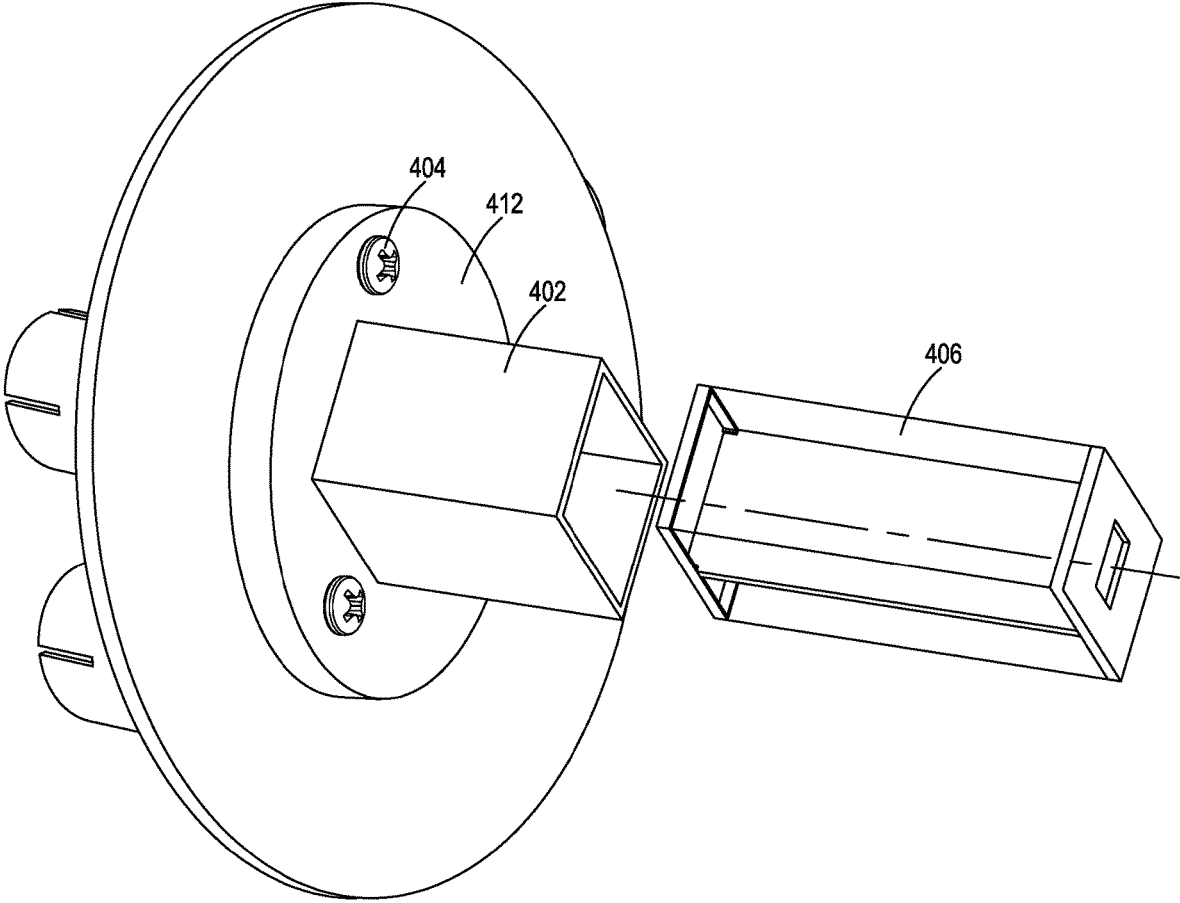

Fig. 7B

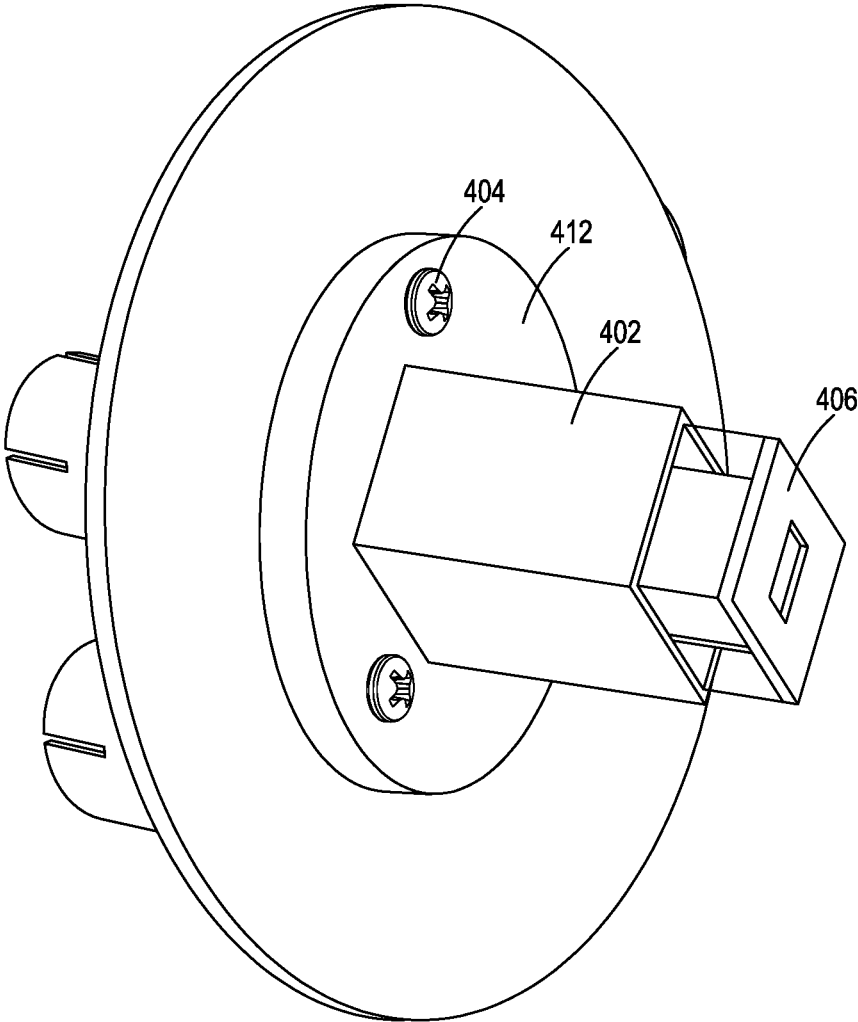

Fig. 7C

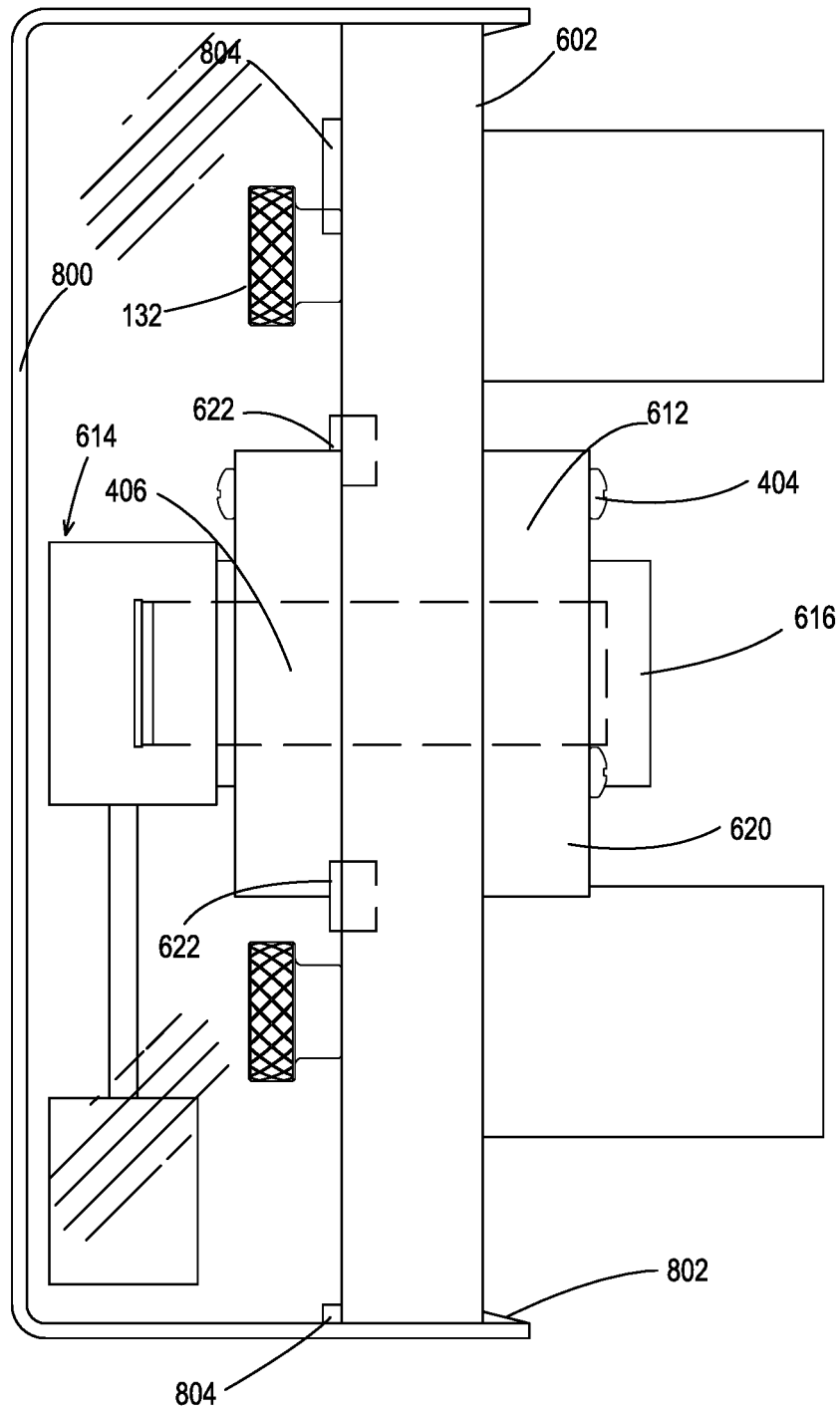

Fig. 8A

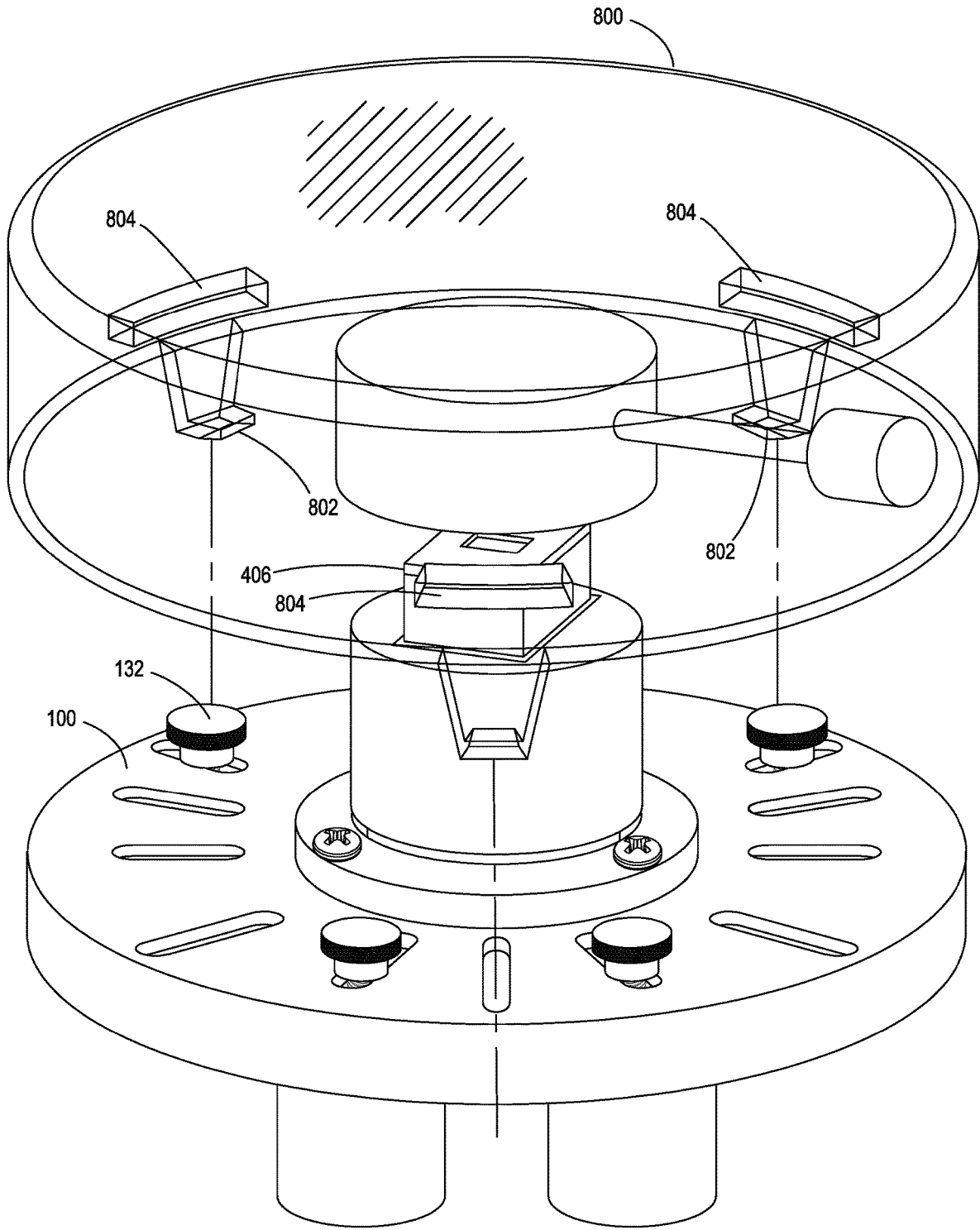

Fig. 8B

**APPARATUS FOR MEASURING
IMBALANCE FORCES OF A TIRE/HUB
ASSEMBLY OF A VEHICLE DURING
MOTION OF THE VEHICLE**

BACKGROUND OF THE INVENTION

“Tire balance” refers to distribution of mass within a vehicle tire or the entire wheel, including the rim, on which the vehicle tire is mounted. Tire balance may also be referred to as “tire unbalance” or “tire imbalance.” As described in U.S. Pat. No. 6,595,053 (Parker), which is incorporated by reference herein, the balancing of vehicle wheel assemblies is most often accomplished by removing the tire/wheel assemblies from the vehicle and mounting each of the tire/wheel assemblies on an off-car balancer. The off-car balancer rotates the tire/wheel assembly, measures the imbalance forces and displays the amount and location of weight to add to the wheel to bring the tire/wheel assembly into a balanced condition. One example of an off-car balancer is The Road Force® Elite wheel balancer, which is commercially available from Hunter Engineering Company, Bridgeton, Mo.

As also described in U.S. Pat. No. 6,595,053, a tire/wheel assembly may be balanced so that it produces negligible forces when rotated on the off-car balancer, but the same assembly may cause significant imbalance forces when mounted on the vehicle and rotated using the vehicle’s bearings and axle. The imbalance forces of a tire/wheel assembly will remain constant between the off-car balancer and the vehicle only if the relationship between the tire/wheel assembly and the axis of rotation is the same for the two mountings. Achieving the desired on-car wheel balance with only an off-car balancer involves both accurately mounting the wheel on the balancer and then accurately mounting the tire/wheel assembly on the vehicle’s hub. Possible causes of wheel-to-vehicle mounting inaccuracy include clearance between the balancer hub and the rim pilot hole, runout of the hub pilot diameter or mounting face, rust or grime between rim and vehicle hub, runout in studs and runout in lug nuts.

As further described in U.S. Pat. No. 6,595,053, on-car balancers can eliminate some of the mounting accuracy problems by performing the balance measurements after the tire/wheel assembly is in its final mounted position on the vehicle. Although on-car balancers are available, they are not very popular because of setup difficulties, operational limitations, and safety issues.

Despite the many efforts made by the industry, including those described in U.S. Pat. No. 6,595,053, there still remains an unmet need for an on-car balancer that is inexpensive, convenient to use, and which can capture parameters necessary for calculating imbalance forces when the vehicle is actually in motion. The present invention fulfills such a need.

SUMMARY OF THE PRESENT INVENTION

In one preferred embodiment, the present invention provides an apparatus configured to be removably attached to a tire/hub assembly of a vehicle via lug nuts of the tire/hub assembly for use in determining imbalance forces of the tire/hub assembly during motion of the vehicle. The apparatus includes a disk, a plurality of cup-shaped objects, and one or more inertial measurement units (IMU’s). Each cup-shaped object is rigidly fixed at one end to the disk and extends perpendicularly outward from the disk. The plural-

ity of cup-shaped objects are arranged a fixed radial distance from the radial center of the disk in a pattern that matches the lug nuts of the tire/hub assembly. Each cup-shaped object is hollow along at least a portion of its length that is distal from the disk. The hollow portion has a diameter that is larger than a diameter of the lug nuts of the tire/hub assembly so as to allow the apparatus to be mounted to the vehicle’s tire/hub assembly by fitting the plurality of cup-shaped objects over the lug nuts of the tire/hub assembly. The one or more IMU’s are mounted to the disk and are configured to measure parameters that are used for calculating the imbalance forces during motion of the vehicle. One or more of the cup-shaped objects may include a magnet fixedly mounted at an end of the cup-shaped objects that is proximate to the disk so as to magnetically engage with one of the lug nuts when the apparatus is attached to the tire/hub assembly of a vehicle, and thereby inhibit the apparatus from coming off of the vehicle when the vehicle is in motion.

BRIEF DESCRIPTION OF THE DRAWINGS

Preferred embodiments of the present invention will now be described by way of example with reference to the accompanying drawings:

FIGS. 1A-1D show a disk for use with the apparatus of the present invention.

FIGS. 2A-2C show details of cup-shaped objects for use with the apparatus, and also show details of how the cup-shaped objects are attached to the disk.

FIG. 2D show details of how the cup-shaped object is fit over a lug nut.

FIG. 2E shows a partial view of an alternative assembly for rapidly attaching the disk to a tire/hub assembly.

FIG. 3A shows prior art tire/hub assemblies.

FIGS. 3B and 3C show how the apparatus of the present invention engages a tire/hub assembly.

FIGS. 4A and 4B show a single, center-mounted IMU of the assembly.

FIGS. 5A and 5B show an alternative embodiment of the assembly having multiple IMU’s.

FIGS. 6A-6L show alternative embodiments of the present invention having a floating center shaft assembly and a single IMU mounted to a radial center of the floating center shaft assembly.

FIGS. 7A-7C show an alternative embodiment of the apparatus having cup-shaped objects that are friction-fit to the lug nuts.

FIGS. 8A and 8B show a cover that may be placed over the wheel-mounted assembly of FIGS. 6A-6F.

DETAILED DESCRIPTION OF THE
INVENTION

Certain terminology is used herein for convenience only and is not to be taken as a limitation on the present invention.

The words “a” and “an”, as used in the claims and in the corresponding portions of the specification, mean “at least one.”

A general overview of one preferred embodiment is described with respect to FIGS. 3A, 3B, 3C, 4A and 4B. FIG. 4B shows a fully assembled apparatus configured to be removably attached to a tire/hub assembly of a vehicle via lug nuts of the tire/hub assembly for use in determining imbalance forces of the tire/hub assembly during motion of the vehicle. The tire/hub assembly and its corresponding lug nuts 304 are best shown in FIG. 3B. In FIGS. 3B and 3C,

element **310** represents a center cutaway of a vehicle rim which is part of the tire/hub assembly. FIG. 3A shows two conventional hub assemblies that may form part of the tire/hub assembly. The upper diagram of FIG. 3A shows a hub with studs, collectively, labeled as **300**. A lug nut **304** is attached to a distal end of each stud. The lower diagram of FIG. 3A shows a hub with threaded holes, collectively, labeled as **302**. A lug bolt **306** is attached to each threaded hole. Not shown in FIGS. 3A and 3B is the tire which is located between the hub **300** and the lug nuts **304** in the upper diagram of FIG. 3A, and between the hub **302** and the ends of the lug bolts **306** in the lower diagram of FIG. 3B. As described herein, the lug nuts **304** perform the same function as the lugs at the end of the lug bolts **306**, and thus they can be considered as equivalent elements.

Referring again to FIGS. 3B, 3C, 4A and 4B, one preferred embodiment of the apparatus in the present invention includes an assembly of the following elements:

- i. a disk **100** (generally cylindrical plate),
- ii. a plurality of cup-shaped objects **202** (also, interchangeably referred to herein as “cups **202**,” and
- iii. one or more IMU’s **406** (an IMU may also be referred to as an “IMU sensor”).

The disk **100** has an outer facing surface **120** and an inner facing surface **122** (labeled in FIG. 2C). The inner facing surface **122** faces the hub **300** when the apparatus is mounted to the vehicle’s tire/hub assembly.

FIGS. 3B and 3C show a partially assembled apparatus that includes the disk **100** and the cup-shaped objects **202**, whereas FIGS. 4A and 4B show all of the above-listed elements i.-iii. In each of these figures, the disk **100** and the cup-shaped objects **202** are part of an overall assembly **230** of thumbscrew **132**, cup **202**, magnet **204**, magnet capture ring **206**, and the appropriately sized adapter **210**, **212**, or **214**, all of which are described in more detail below.

Each cup-shaped object **202** is rigidly fixed at one end to the disk **100** and extends perpendicularly outward from the disk **100**. The plurality of cup-shaped objects **202** are arranged a fixed radial distance from the radial center of the disk **100** in a pattern that matches the lug nuts **304** of the tire/hub assembly. Each cup-shaped object **202** is hollow along at least a portion of its length that is distal from the disk **100**. The hollow portion has a diameter that is slightly larger than a diameter of the lug nuts **304** of the tire/hub assembly so as to allow the apparatus to be mounted to the vehicle’s tire/hub assembly by fitting the plurality of cup-shaped objects **202** over the lug nuts **304** of the tire/hub assembly, as best illustrated in FIGS. 3B and 3C. The one or more IMU’s **406** are mounted to the disk **100**, as best illustrated in FIGS. 4A and 4B, and are configured to measure parameters that are used for calculating the imbalance forces during motion of the vehicle. In the embodiment of FIGS. 4A and 4B, a single IMU **406** is mounted in a center of the disk **100**. Other embodiments that use multiple IMU’s are described below with respect to FIGS. 5A and 5B.

The one or more IMU’s **406** may be mounted to the disk **100** in any suitable manner. In the embodiment of FIGS. 4A and 4B, the single IMU **406** is mounted to the outer facing surface **120** of the disk **100** via IMU housing **402**. The IMU housing **402** has a rectangular-shaped slot **410** and mounting plate **412** formed as one piece. The mounting plate **412** is attached via screws **404** to a center portion of the outer facing surface **120** of disk **100**. The slot **410** receives the IMU **406**, as illustrated in FIG. 4A which shows the IMU **406** exploded from the slot **410**, and FIG. 4B which shows the IMU **406** fully inserted into the slot **410**. The IMU **406**

is securely retained in the slot **410** by any suitable means, such as friction fit, clamps, holding screws, or hook and loop fastener material.

FIGS. 5A and 5B show another embodiment of the apparatus wherein there are three IMU’s **510** arranged in an equilateral triangle configuration, wherein each IMU is equidistant from the center of the disk **100**. In this manner, each IMU is placed at 120 degree angles from the center of the disk **100**. FIG. 5A shows one mounting embodiment wherein the three IMU’s **510** are fixed to mounting flange **504**, which is then attached to mounting plate **512** via a center hole **513** in the mounting plate **512**. FIG. 5B shows the fully assembled view.

Lug nut configurations differ among vehicles in at least the following ways:

- i. number of lug nuts
- ii. diameter of the lug nuts
- iii. radial distance of the lug nuts from the center of the hub

iv. lug patterns, namely, the arrangement of lug nuts along the fixed radius from the center of the hub (typically equidistant, but not always)

These parameters result in a large number of permutations of potential lug nut configurations. However, there are a handful of well-known configurations that cover a large percentage of vehicles. The assembly has various features to allow for its use with many different common configurations, as described below.

FIG. 1A shows the disk **100** by itself. The disk **100** includes a center opening **112** and device mounting holes **114** for receiving the screws **404** shown in FIGS. 4A, 4B, 5A, and 5B. The disk also includes the following slots:

- i. slot **102** for use with a 4, 5, or 6 lug patterns
- ii. slot **104** for use with 4 and 6 lug patterns
- iii. slot **106** for use with 5 lug patterns
- iv. slot **108** for use with 6 lug patterns
- v. slot **110** for use with 4 lug patterns

The various lug patterns are also represented by letters A, B, and C.

To allow for interchangeability, the cup-shaped objects **202** are removably attachable to the disk **100** to allow a set of cup-shaped objects **202** to be reconfigured on the disk **100** to match the appropriate lug nut configuration for a particular vehicle. Likewise, different sets of cup-shaped objects **202** can be provided having different diameters to accommodate different diameter lug nuts **304**. The slots **102-100** allow for changing the radial distance of the lug nuts from the center of the hub, as opposed to providing holes that would only accommodate one radial distance.

FIGS. 1B-1D show thumbscrews **132** which are used to fasten the cup-shaped objects **202** to the disk **100**, as described below. FIG. 1B shows a 4 lug pattern that requires four thumbscrews **132** (one for each cup-shaped object **202**), FIG. 1C shows a 5 lug pattern that requires five thumbscrews **132** (one for each cup-shaped object **202**), and FIG. 1D shows a 6 lug pattern that requires six thumbscrews **132** (one for each cup-shaped object **202**).

FIGS. 2A-2D show additional details of the cup-shaped objects **202**, and they also show details of how the cup-shaped objects **202** are attached to the disk **100**. The example in FIGS. 2A-2D uses the 5 lug pattern of FIG. 1B. FIG. 2A is an exploded top view of the apparatus, FIG. 2B is a fully assembled top view of the apparatus, FIG. 2C is fully assembled bottom view of the apparatus, and FIG. 2D is an exploded view of different lug nut adapters (described below) for use with the cup-shaped object **202**.

5

FIG. 2A shows five thumbscrews **132** which are used to fasten five cup-shaped objects **202** to the disk **100**. Each thumbscrew **132** is inserted through an appropriate slot **102** or **106** associated with the 5 lug pattern of FIG. 1B, and is screwed into threaded holes **224** shown in phantom in a center of a distal portion of each cup-shaped object **202**. When fully screwed in, a flange of each thumbscrew **132** is flush against the outer facing surface of the disk **100**, and each thumbscrew **132** securely holds its respective cup-shaped object against the inner facing surface **122** of the disk **100**, as shown in FIG. 2C.

FIG. 2A also shows magnet **204**, magnet capture ring **206**, and lug nut adapter **208** that are received inside each of the respective cup-shaped objects **202**. The magnet **204** and magnet capture ring **206** form a magnet assembly **207** that is placed in a pocket area of the cup-shaped object **202** so as to be flush against a distal end surface of the cup-shaped object **202** (top portion of the cup-shaped object **202** when viewed in FIG. 2A, bottom portion of the cup-shaped object **202** when viewed in FIG. 2B). The magnet **204** is thus fixedly mounted at an end of the cup-shaped object **202** that is proximate to the disk **100**. The magnet assembly **207** is held in place within the cup-shaped object **202** by friction fit. Adhesive may alternatively be used for this purpose. In use, the magnets **204** magnetically engage with the lug nuts **304** when the apparatus is attached to the tire/hub assembly of a vehicle, and thereby inhibit the apparatus from coming off of the vehicle when the vehicle is in motion. In one preferred embodiment, there is a magnet **204** in each cup-shaped object **202**. However, depending upon the strength of the magnets **204**, it may not be necessary to provide magnets **204** in each cup-shaped object.

FIG. 2A also shows a lug nut adapter mounted inside each cup-shaped object **202**. As discussed above, lug nuts come in a variety of different head diameters. To avoid excessive play when the apparatus is attached to the tire/hub assembly of a vehicle, an appropriately sized hollow lug nut adapter **208** is selected for the lug nuts of the vehicle so as to provide a snug fit, but not necessarily a friction fit. This also helps to ensure that IMU **406** or IMU's **510** are symmetrically arranged with respect to a center axis of the tire/hub assembly. The lug nut adapter **208** may be removable to allow for different sized adapters to be used with the same cup-shaped object **202** and may be held in place within the cup-shaped object **202** by friction fit. Alternatively, the lug nut adapter **208** may be permanently assembled within the cup-shaped object **202**. If so, different cup-shaped objects **202** will be required for lug nuts of different head diameters.

The cup-shaped objects (cups) **202** have a depth of length, labeled as "L" in the leftmost cup **202** of FIG. 2A that is sufficient to accommodate a thread portion for receiving the thumbscrew **132**, the magnet assembly **207**, and the full depth of the lug nut **304**.

FIG. 2B is a fully assembled top view of the apparatus of FIG. 2A, and FIG. 2C is a fully assembled bottom view of the apparatus of FIG. 2A. In FIGS. 2B and 2C, element **230** refers to the assembly of the thumbscrew **132**, cup **202**, magnet **204**, magnet capture ring **206**, and the appropriately sized adapter **210**, **212**, or **214**.

FIG. 2D shows examples of three different lug nut adapters **210**, **212** and **214** for use with the same cup-shaped object **202**. The uppermost diagram shows lug nut adapter **210** for accommodating a 17 mm lug nut **216**, the middle diagram shows a lug nut adapter **212** for accommodating a $\frac{7}{8}$ inch lug nut **218**, and the bottommost diagram shows a lug nut adapter **214** for accommodating a $\frac{15}{16}$ inch lug nut

6

222. The lug nut adapters **210**, **212** and **214** provide the same functionality as the lug nut adapter **208** described above and shown in FIG. 2A.

FIG. 2E shows a partial view of an alternative assembly for rapidly attaching disk **100** to a tire/hub assembly when time-is-of-the-essence, particularly when interchangeability is due to different vehicles and varying hub/lug configurations are sequentially encountered and the threading and/or unthreading of thumbscrews, nuts, and cups, is impractical and labor intensive. Cup **202** still contains magnet **204**, magnet capture ring **206**, and may or may not require lug nut adapter **208** for attachment to vehicle lug nuts. Instead of a threaded type of attachment as shown in FIG. 2A, FIG. 2E shows cup **202** having an affixed cylindrical shaft **234** that passes through slot **106** of disk **100**. Magnetically locking cylinder **240** is pressed onto cylindrical shaft **234** through hole **236** and is firmly held in place because the disk facing surface **238** of the ring magnet **242** is the opposite polarity of the disk facing surface **232** of magnet **204**, thereby producing a strong magnetic clamp. All contact surfaces of cup **202**, disk **100**, and magnetic locking cylinder **240** may have abrasive or geometrically opposite mating surfaces to decrease lateral slippage when magnetically clamped.

The materials for constructing certain parts of the apparatus such as the disk **100**, cup-shaped objects **202**, and IMU housing **402** are preferably rigid and durable so as to withstand movement on a vehicle with minimal play. One suitable material is a thermoplastic polymer, such as acrylonitrile butadiene styrene (ABS). The selected material must also not cause interference with the electronics of the IMU's. ABS has electrical insulation properties that are well-suited to the operating environment of the apparatus.

FIGS. 7A-7C show another embodiment of the apparatus of the present invention that includes an assembly of the following elements:

- i. disk **100** (generally cylindrical plate),
- ii. a plurality of cup-shaped objects **202**, and
- iii. one or more IMU's **406** (an IMU may also be referred to as an "IMU sensor").

The embodiment of FIGS. 7A-7C differs from the embodiment described above in that the disk **100** and the cup-shaped objects **202** are preferably formed as a single unit, such as by injection molding. Since the cup-shaped objects **202** are not removable, the single unit will be limited in use to a particular lug nut pattern. However, fabrication costs may be lower due to the reduced number of parts, the elimination of any need for creating slots in the disk **100**, and the relative inexpensiveness of injection molding. The remaining parts of the apparatus of FIGS. 7A-7C are the same as the embodiment described below, namely, the IMU housing **402** that is mounted to the single unit via screws **404**, and that receives the IMU **406**, as illustrated in FIGS. 7B and 7C. Alternatively, the single unit may have the multiple IMU embodiment shown in FIGS. 5A and 5B attached thereto.

The embodiment of FIGS. 7A-7C also differs from the embodiment described above in that the cup-shaped objects **202** are designed to be friction fit over the lug nuts **304** of the vehicle, or over only a subset of the lug nuts of the vehicle. For example, various models of the Ford® F150 truck have a six lug pattern. The embodiment of FIGS. 7A-7C provides four cup-shaped objects **202** that friction fit over four of the six lug nuts **304** in a manner similar to a conventional decorative center cap that is commercially available for such a vehicle. Instead of using magnets inside of the cup-shaped objects **202** for releasably attaching the apparatus to the lug nuts **304**, the cup-shaped objects **202**

include a plurality of slits or slots **700** which allow sidewall sections **702** of each cup-shaped object **202** to slightly flex outward to provide the friction fit. In the embodiment shown in FIGS. 7A-7C, each cup-shaped object **202** has four slits or slots **700** that define four sidewall sections **702**.

The embodiment of FIGS. 7A-7C may also be able to accommodate different sized lug nut adaptors, such as illustrated in FIG. 2D. However, for such adaptors to work, the adaptors are preferably also constructed with matching slits or slots that align with the slits or slots **700** of the cup-shaped object **202**, so that the sidewalls of the two parts (i.e., the adaptor and the cup-shaped object **202**) slightly flex outward in unison to provide the friction fit.

In the embodiments described above, the IMU's are rigidly attached to the disk **100** so that they rotate with the disk **100** when the vehicle is in motion.

In alternative embodiments, the IMU's are mounted to the disk **100** in a manner that allows them to remain relatively stationary, in a manner similar to a hubometer (also, known as a hubodometer). These embodiments are referred to more generally as having a "non-rotating IMU" and as having a "floating center shaft assembly." These embodiments are all described with respect to a single IMU **406** mounted in a center of the disk **100**. For ease of nomenclature, the combination of the disk **100** and the cup-shaped objects **202** is referred to as "wheel-mounted assembly **602**."

FIGS. 6A-6C show one embodiment of an apparatus **600** that includes a non-rotating IMU/floating center shaft assembly. A floating center shaft **616** extends through a center of the wheel-mounted assembly **602**. Two sets of bearings **612**, shown in phantom in FIGS. 6B and 6C, are provided within the floating center shaft **616**. The bearings **612** are inside of bearing cap **620**. A weight stabilization assembly **614** includes a hub portion **615** that is attached to the distal end of the floating center shaft **616**, a downward facing shaft **617** (meaning, downward facing when in operation) which can be rigid or flexible, and a contoured weight **618** fixed to a distal end of the downward facing shaft **617**. A top view of the contoured weight **618** is also shown in a separate figure within FIGS. 6B and 6C. The non-rotating IMU **406** is attached to weight stabilization assembly **614** in the center of wheel-mounted assembly **602**, as shown in phantom in FIG. 6A.

In one preferred embodiment, the disk portion of the wheel-mounted assembly **602** further includes a pair of magnets **622** mounted thereon in an opposed manner along a radial line extending through the radial center of the wheel-mounted assembly **60**, that is, a fixed radial distance from the radial center of the disk portion. In this embodiment, the IMU **406** further includes a Hall effect sensor (not shown) that works in conjunction with the magnets to measure rotational speed of the wheel-mounted assembly **602** during motion of the vehicle.

FIG. 6A is a front elevation view of the apparatus **600**. FIG. 6B is a side elevation view of the apparatus **600** and shows the weight stabilization assembly **614** exploded from the wheel-mounted assembly **602** and the floating center shaft **616**. FIG. 6C is also a side elevation view of the apparatus **600** and shows the weight stabilization assembly **614** attached to the wheel-mounted assembly **602** and the floating center shaft **616**.

FIGS. 6D-6F show another embodiment of an apparatus **630** that also includes a non-rotating IMU/floating center shaft assembly. This embodiment is similar to the embodiment of FIGS. 6A-6C, except that it relies upon an airfoil stabilizing structure **634**, instead of the weight stabilization assembly **614**, for stabilization of the IMU **406**. The airfoil

stabilizing structure **634** comprises hub portion **636** and airfoil **632**. The hub portion **636** and the airfoil **632** perform comparable functions as the hub portion **615** and the contoured weight **618** of the embodiment in FIGS. 6A-6C. The geometry of the airfoil stabilizing structure **634** is an example representation only.

FIG. 6D is a front elevation view of the apparatus **630**. FIG. 6E is a side elevation view of the apparatus **630** and shows the airfoil stabilizing structure **634** exploded from the wheel-mounted assembly **602** and the floating center shaft **616**. FIG. 6C is also a side elevation view of the apparatus **600** and shows the airfoil stabilizing structure **634** attached to the wheel-mounted assembly **602** and the floating center shaft **616**.

FIGS. 6G-6I show another embodiment of an apparatus **640** that also includes a non-rotating IMU/floating center shaft assembly. This embodiment includes both of the stabilizing structures shown in FIGS. 6A-6C and 6D-6F. These figures are thus self-explanatory in view of the descriptions above of the two respective embodiments. The same hub portion is used for both stabilizing structures, and thus this element is labeled as hub portion **615/636**. The three different views in FIGS. 6G-6I are similar to the three different views of FIGS. 6A-6C and 6D-6F, and thus are not described further. The embodiment of FIGS. 6G-6I is also shown with the magnets **622**.

FIG. 6J shows a front and side elevation view of only the weight stabilization assembly **614** used in FIGS. 6A-6C. FIG. 6K shows a front and side elevation view of only the airfoil stabilizing structure **634** used in FIGS. 6D-6F. FIG. 6L shows a front and side elevation view of the combined weight stabilization assembly **614** and airfoil stabilizing structure **634** used in FIGS. 6G-6I.

FIGS. 8A and 8B show a clear cover **800** that may be placed over the wheel-mounted assembly **602** shown in FIGS. 6A-6C to reduce road turbulence that may cause the stationary IMU **406** to oscillate. The cover **800** may be secured to the wheel-mounted assembly **602** via cover tabs **802** that are molded into cover **800**. A similar type of cover **800** may also be used with the embodiment FIGS. 6D-6F. The cover tabs **802** snap over the back of the wheel-mounted assembly **602** to secure it in place. Inside of the cover **800**, approximately $\frac{3}{8}$ " from the opening, are three raised stops **804** that rest on the front side of the wheel-mounted assembly **602**. The stops **804** keep the cover **800** in the required position over the wheel-mounted assembly **602**, preventing the cover **800** from making contact with the weight stabilization assembly **614**.

In one preferred embodiment, the cup-shaped objects **202** are cylindrically shaped, and define cylinders having solid circumferential sidewalls. However, the cup-shaped objects **202** can have other shapes, such as square or octagonal, since other shapes would still allow them to releasably engage lug nuts, particularly when using the magnetic attachment embodiment. Likewise, the lug nut adapters may have a suitable internal diameter shape so as to snugly fit over the lug nuts, while having a different external diameter shape to conform to the shape of the cup-shaped objects **202**.

In selected embodiments disclosed above, the cup-shaped objects **202** are rigidly fixed to the disk **100** via threaded bolts, such as thumbscrews. However, other ways to fasten the cup-shaped objects **202** to the disk **100** are within the scope of the invention, such as nuts and bolts, and adhesives. In an alternative embodiment, an integrally formed thread may extend from a distal end of the cup-shaped object **202**, and the cup-shaped object **202** may be fastened to the disk

by inserting the thread through the hole in the disk **100** and fastening it using a nut on the opposite side of the disk **100**.

In other embodiments, such as shown in FIGS. 7A-7C, the cup-shaped objects **202** and the disk **100** are formed as a unitary piece, and thus no fastening mechanism is needed.

The magnetic attachment embodiment is only one preferred structure for removably attaching the apparatus to the tire/hub assembly of the vehicle via the lug nuts of the tire/hub assembly. The scope of the present invention includes other attachment mechanisms that rely upon physical (as opposed to magnetic) attachment of the apparatus to the tire/hub assembly of the vehicle via the lug nuts of the tire/hub assembly, such as clamping mechanisms, and other types of physical fastening mechanisms.

Any IMU may be used that has a form factor and durability suitable for the environment described herein. One suitable IMU is the IMU described in U.S. Pat. No. 10,284,752 (Canfield et al.), which is incorporated herein by reference. Sample measured parameters that are used for calculating the imbalance forces during motion of the vehicle include, and which are captured by the IMU's include, but are not limited to, acceleration and angular rotation. The data captured by the IMU may then be used for at least the following purposes:

i. Determine where correction weights should be attached to the rim of the wheel to achieve improved balancing of the tire/hub assembly.

ii. Determine if the tire/hub assembly is so far out of balance that normal balancing (adding of correction weights) cannot correct the imbalance.

In use, the different embodiments of the apparatuses (referred to herein in the singular) are removably attached to a tire/hub assembly of a vehicle via lug nuts of the tire/hub assembly. The vehicle is then driven on a road surface, and during motion of the vehicle, parameters measured by the one or more inertial measurement units (IMU's) mounted to the disk of the apparatus are collected, and then subsequently used for calculating the imbalance forces.

It will be appreciated by those skilled in the art that changes could be made to the embodiments described above without departing from the broad inventive concept thereof. It is understood, therefore, that this invention is not limited to the particular embodiments disclosed, but it is intended to cover modifications within the spirit and scope of the present invention.

What is claimed is:

1. An apparatus configured to be removably attached to a tire/hub assembly of a vehicle via lug nuts of the tire/hub assembly for use in determining imbalance forces of the tire/hub assembly during motion of the vehicle, the apparatus comprising:

(a) a disk;

(b) a plurality of cup-shaped objects, each cup-shaped object being rigidly fixed at one end to the disk and extending perpendicularly outward from the disk, the plurality of cup-shaped objects being arranged a fixed radial distance from a radial center of the disk in a pattern that matches the lug nuts of the tire/hub assembly, each of the cup-shaped objects being hollow along at least a portion of its length that is distal from the disk, the hollow portion having a diameter that is larger than a diameter of the lug nuts of the tire/hub assembly so as to allow the apparatus to be mounted to the vehicle's tire/hub assembly by fitting the plurality of cup-shaped objects over the lug nuts of the tire/hub assembly; and

(c) one or more inertial measurement units (IMU's) mounted to the disk and configured to measure param-

eters that are used for calculating the imbalance forces during motion of the vehicle,

wherein one or more of the cup-shaped objects includes a magnet fixedly mounted at an end of the cup-shaped objects proximate to the disk so as to magnetically engage with one of the lug nuts when the apparatus is attached to the tire/hub assembly of the vehicle, and thereby inhibit the apparatus from coming off of the vehicle when the vehicle is in motion.

2. An apparatus configured to be removably attached to a tire/hub assembly of a vehicle via lug nuts of the tire/hub assembly for use in determining imbalance forces of the tire/hub assembly during motion of the vehicle, the apparatus comprising:

(a) a disk;

(b) a plurality of cup-shaped objects, each of the cup-shaped objects being rigidly fixed at one end to the disk and extending perpendicularly outward from the disk, the plurality of cup-shaped objects being arranged a fixed radial distance from a radial center of the disk in a pattern that matches the lug nuts of the tire/hub assembly, each of the cup-shaped objects being hollow along at least a portion of its length that is distal from the disk, the hollow portion having a diameter that is larger than a diameter of the lug nuts of the tire/hub assembly so as to allow the apparatus to be mounted to the vehicle's tire/hub assembly by fitting the plurality of cup-shaped objects over the lug nuts of the tire/hub assembly; and

(c) a plurality of inertial measurement units (IMU's) mounted to the disk and configured to measure parameters that are used for calculating the imbalance forces during motion of the vehicle,

wherein the plurality of IMU's are mounted to the disk a fixed radial distance from the radial center of the disk in an evenly spaced pattern, and wherein the plurality of IMU's rotate with the disk during motion of the vehicle.

3. An apparatus configured to be removably attached to a tire/hub assembly of a vehicle via lug nuts of the tire/hub assembly for use in determining imbalance forces of the tire/hub assembly during motion of the vehicle, the apparatus comprising:

(a) a disk;

(b) a plurality of cup-shaped objects, each of the cup-shaped objects being rigidly fixed at one end to the disk and extending perpendicularly outward from the disk, the plurality of cup-shaped objects being arranged a first fixed radial distance from a radial center of the disk in a pattern that matches the lug nuts of the tire/hub assembly, each of the cup-shaped objects being hollow along at least a portion of its length that is distal from the disk, the hollow portion having a diameter that is larger than a diameter of the lug nuts of the tire/hub assembly so as to allow the apparatus to be mounted to the vehicle's tire/hub assembly by fitting the plurality of cup-shaped objects over the lug nuts of the tire/hub assembly;

(c) a floating center shaft assembly attached to the disk; and

(d) a single inertial measurement unit (IMU) mounted to a radial center of the floating center shaft assembly and configured to measure parameters that are used for calculating the imbalance forces during motion of the vehicle,

11

wherein the floating center shaft assembly inhibits rotational movement of the single IMU during motion of the vehicle.

4. The apparatus of claim 3 wherein the disk includes a plurality of holes that define a lug nut pattern so as to allow the plurality of cup-shaped objects to be rigidly fixed to the disk in locations that correspond with the lug nut pattern.

5. The apparatus of claim 4 wherein each of the cup-shaped objects includes a hole at the one end, and each of the plurality of cup-shaped objects are removably attached to the disk via a fastener extending through one of the holes in the disk and also through the hole at the one end of the cup-shaped object.

6. The apparatus of claim 5 wherein the fastener is a threaded bolt, and the hole in the one end of the cup-shaped object includes threads for receiving the threaded bolt.

7. The apparatus of claim 3 wherein the cup-shaped objects are cylindrically shaped.

8. The apparatus of claim 7 wherein the cup-shaped objects are cylinders having solid circumferential sidewalls.

9. The apparatus of claim 3 wherein the disk includes a plurality of holes that define a plurality of different sets of lug nut patterns so as to allow the plurality of cup-shaped objects to be rigidly fixed to the disk in locations that correspond with the lug nut pattern of the tire/hub assembly of the vehicle that the apparatus is removably attached to.

12

10. The apparatus of claim 9 wherein the plurality of holes are slot-shaped.

11. The apparatus of claim 3 wherein the floating center shaft assembly includes a weight stabilization assembly attached thereto for stabilization of the single IMU during motion of the vehicle.

12. The apparatus of claim 3 wherein the floating center shaft assembly includes an airfoil stabilizing structure attached thereto for stabilization of the single IMU during motion of the vehicle.

13. The apparatus of claim 3 wherein the single IMU includes a Hall effect sensor, and the disk includes a pair of magnets mounted thereon in an opposed manner a second fixed radial distance from the radial center of the disk, the Hall effect sensor and the magnets being used to measure rotational speed of the apparatus during motion of the vehicle.

14. The apparatus of claim 3 wherein one or more of the cup-shaped objects includes a magnet fixedly mounted at an end of the cup-shaped objects proximate to the disk so as to magnetically engage with one of the lug nuts when the apparatus is attached to the tire/hub assembly of a vehicle, and thereby inhibit the apparatus from coming off of the vehicle when the vehicle is in motion.

* * * * *